Experimental Status & Future of Generalized Parton Distributions

SUPA lectures, Glasgow University, May 17+24, 2007

Wolf-Dieter Nowak

DESY, 15738 Zeuthen, Germany

`Wolf-Dieter.Nowak@desy.de`

Table of Contents

- ▷ Motivation: angular momentum structure of the nucleon
- ▷ Exp. Status on parton distributions
- ▷ Kinematic coverage of DVCS experiments
- ▷ HERMES spectrometer & Recoil Detector
- ▷ DVCS Azimuthal asymmetries
- ▷ Beam-charge and beam-spin asymmetries, nuclear DVCS
- ▷ Longitudinal and transverse target-spin asymmetries
- ▷ Model-dependent constraint on J_u vs. J_d
- ▷ Exclusive scalar and vector meson production
- ▷ Summary and Outlook

Angular Momentum Structure of the Nucleon

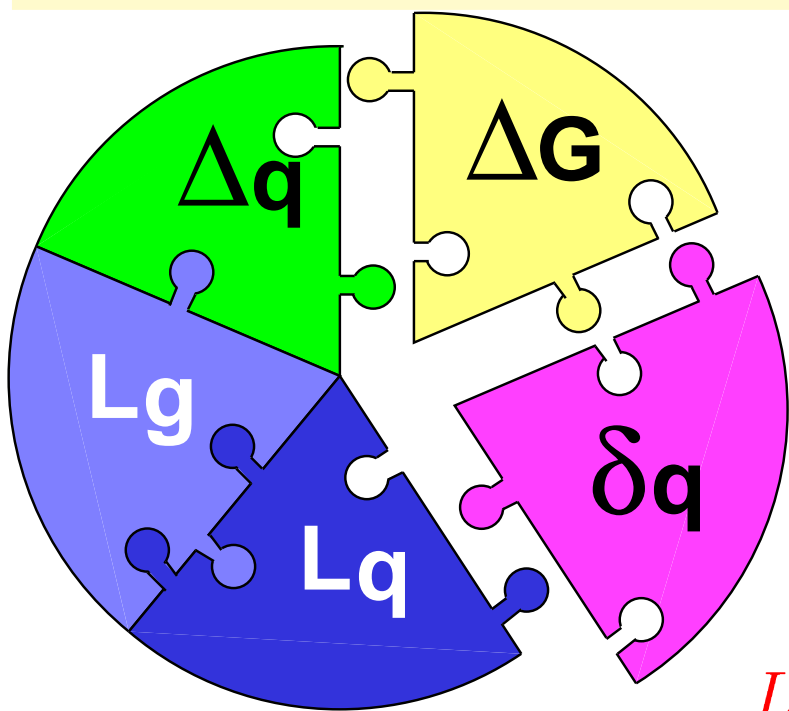

Proton Spin

$$\frac{1}{2} = \frac{1}{2} \underbrace{(\Delta u + \Delta d + \Delta s)}_{\sim 30\% \text{ } J_q} + L_q + \underbrace{\Delta G + L_g}_{J_g}$$

Δq : known from DIS & SIDIS

ΔG : first indications from DIS and pp

L_q, L_g : unknown!

Generalized Parton Distributions $\Rightarrow J_q, J_g$

Ji's relation — Ji, PRL 78 (1997) 610

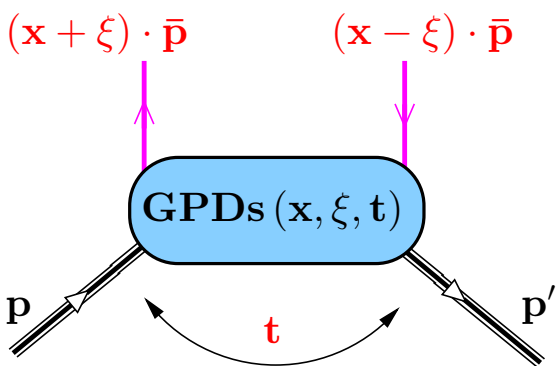

$$J_{q,g} = \frac{1}{2} \lim_{t \rightarrow 0} \int_{-1}^1 dx \cdot x \cdot [H_{q,g}(x, \xi, t) + E_{q,g}(x, \xi, t)]$$

Exp. Status on Parton Distribution Functions

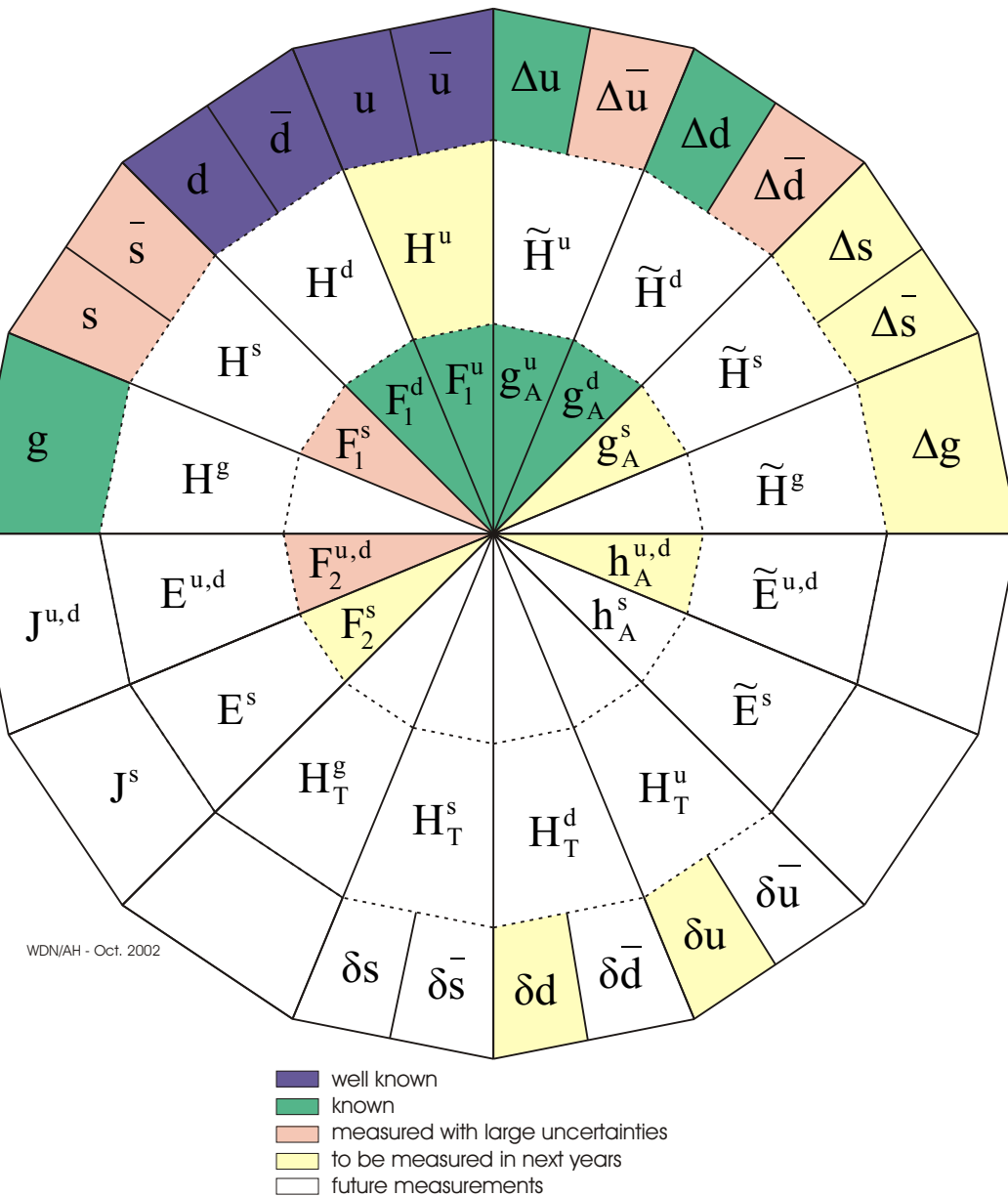

Improvement over last 5 years:

- spin-independent & helicity PDFs:
 - COMPASS: $\frac{\Delta g}{g}$
 - HERMES: $\Delta u, \Delta d, \Delta s, \frac{\Delta g}{g}$
 - JLab: $\Delta u, \Delta d$ at large x
 - transversity & friends:
 - HERMES: Sivers function
 - BELLE: Collins (fragm.) function
 - GPDs:
 - CLAS, HERMES, (H1/ZEUS): first look on H, \tilde{H}, E
- ⇒ much more to come ...

Kinematic Coverage of DVCS Experiments

Fixed-target kinematics

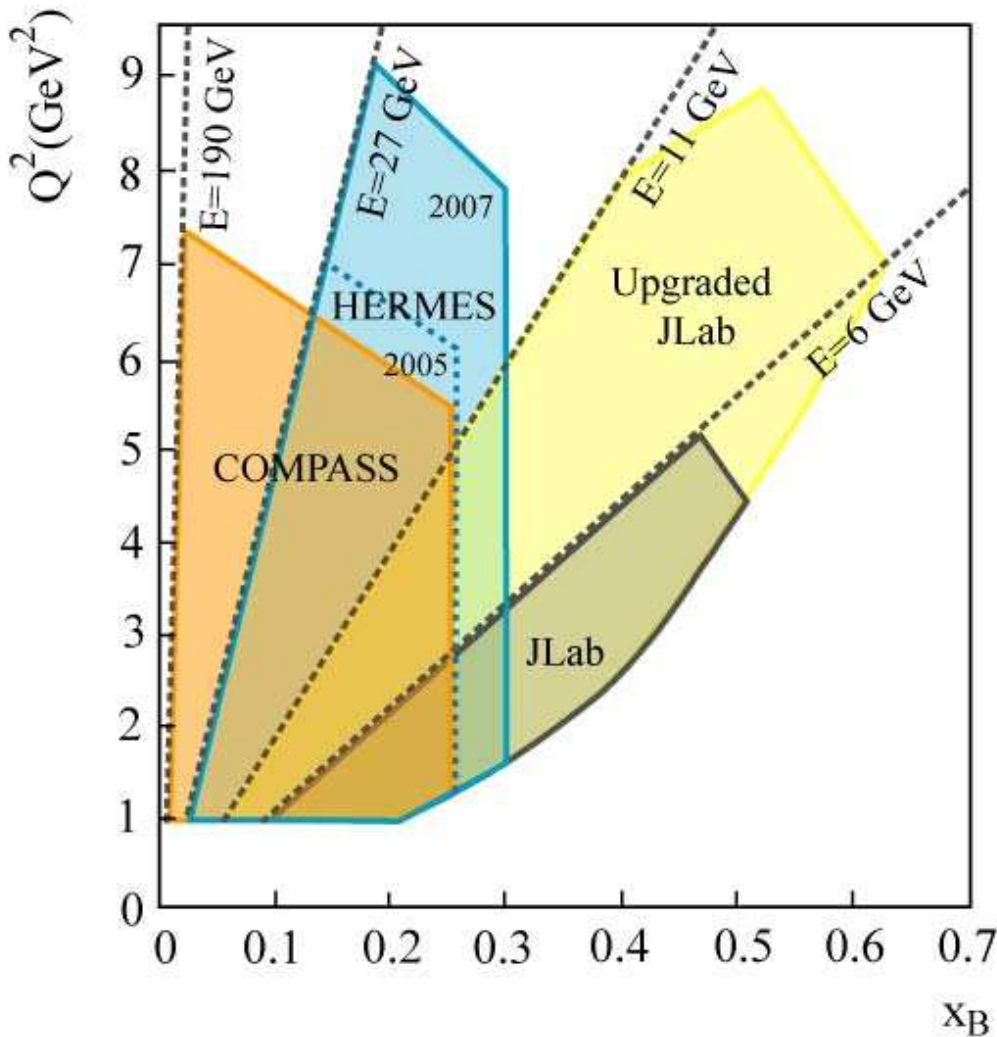

Fixed-target experiments:

$$x > 0.03, Q^2 < 10 \text{ GeV}^2$$

- **COMPASS**: low + medium x_B
- **HERMES**: medium x_B , higher Q^2
- **JLab**: medium+large x_B , lower Q^2
- **JLab 11 GeV**: larger x_B , higher Q^2

Collider experiments H1+ZEUS:

$$x_B < 0.01, Q^2 : 5 \dots 100 \text{ GeV}^2:$$

- small skewness
- ⇒ almost forward GPDs !

⇒ fixed-target experiments essential to study non-forward region of GPDs !

⇒ **only COMPASS can explore low- x !**

The HERMES Spectrometer

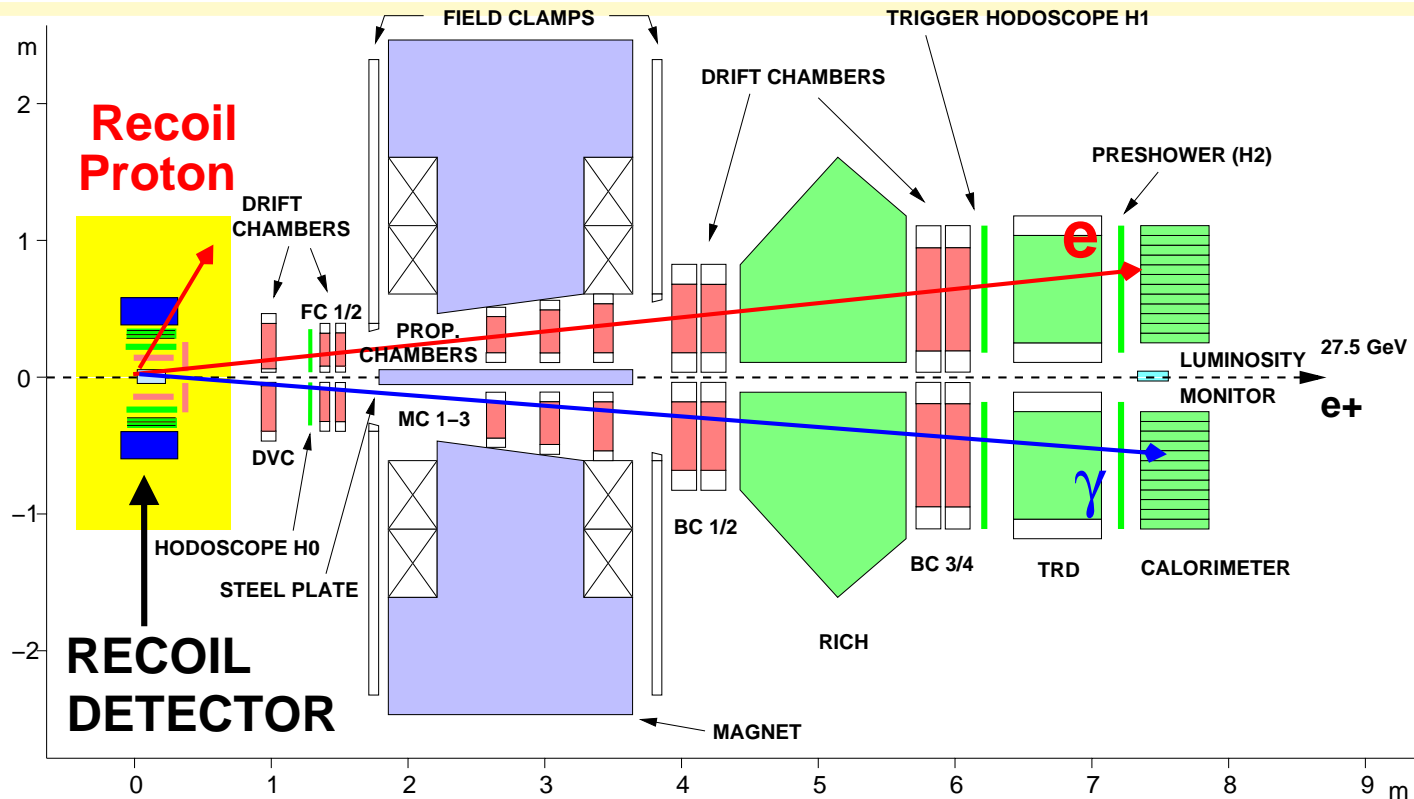

- Pure gas target: **polarized H, D**; unpolarized H, D, N, Ne, Kr, Xe
- Forward spectrometer: $40 \text{ mrad} \leq \Theta \leq 220 \text{ mrad}$
- Tracking: $\mathcal{O}(50)$ tracking planes per half spectrometer: $\delta p/p \sim 2\%$, $\delta\Theta \leq 1 \text{ mrad}$
- PID for e^\pm : TRD, Preshower, Calorimeter
- PID for π^\pm, K^\pm, p : Dual-radiator Ring-imaging Cherenkov ($2 < p < 15 \text{ GeV}$)

New Recoil Detector at HERMES

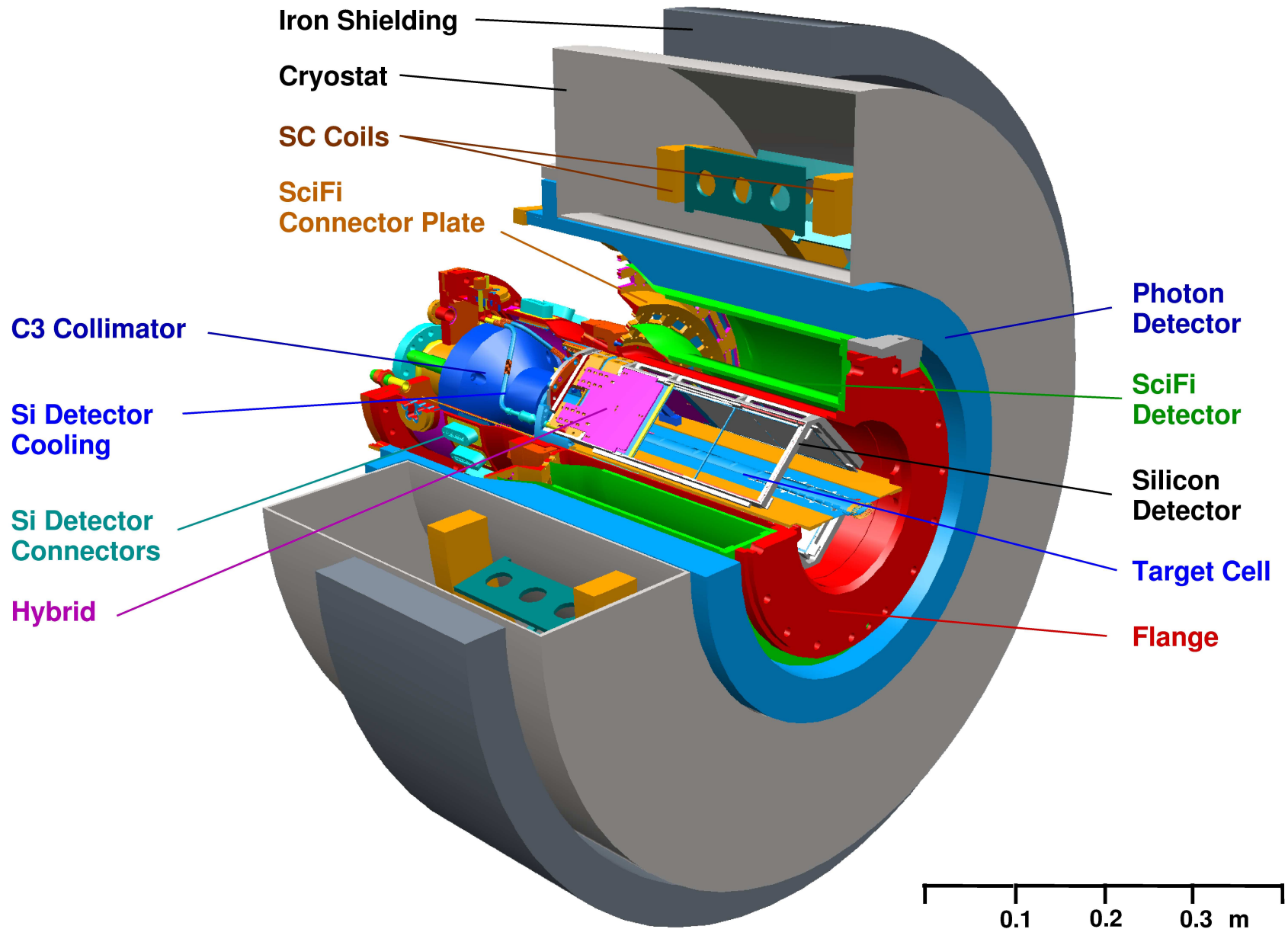

HERMES Recoil Detector Goals I

For the study of DVCS and exclusive meson production, detect over largest possible momentum range and at best possible t -resolution:

- Recoil protons (76% azim. acceptance, $135 < p < 1200$ MeV/c)
- Pions and protons from background processes (p/π PID via $\frac{dE}{dx}$)
- Photons from $\pi^0 \rightarrow \gamma\gamma$

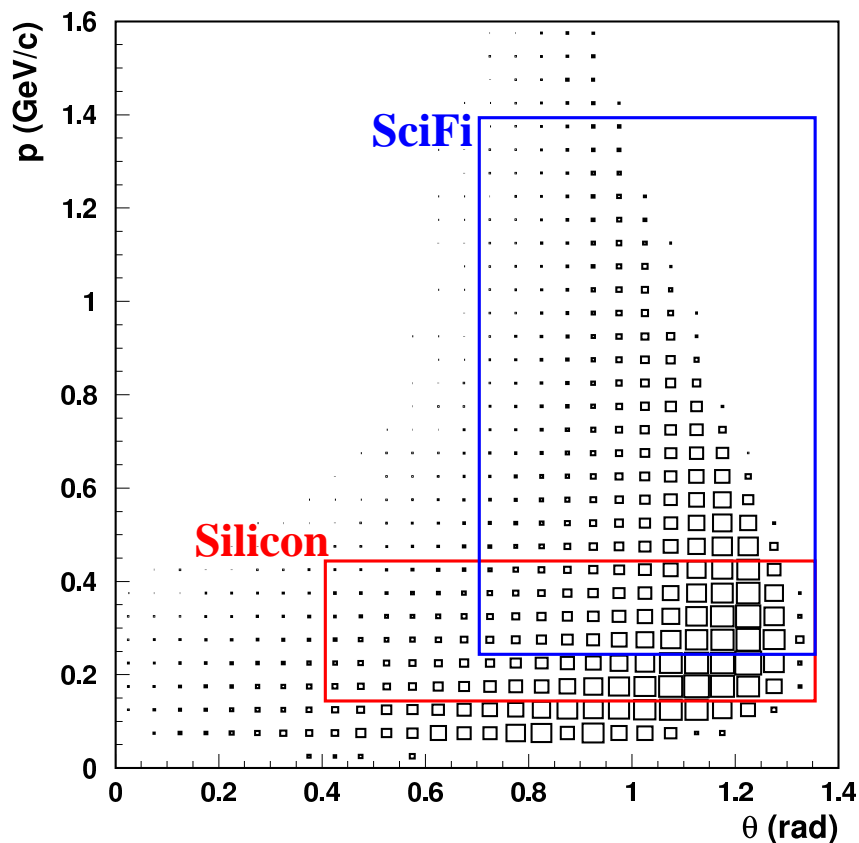

Resolution from Monte Carlo studies:

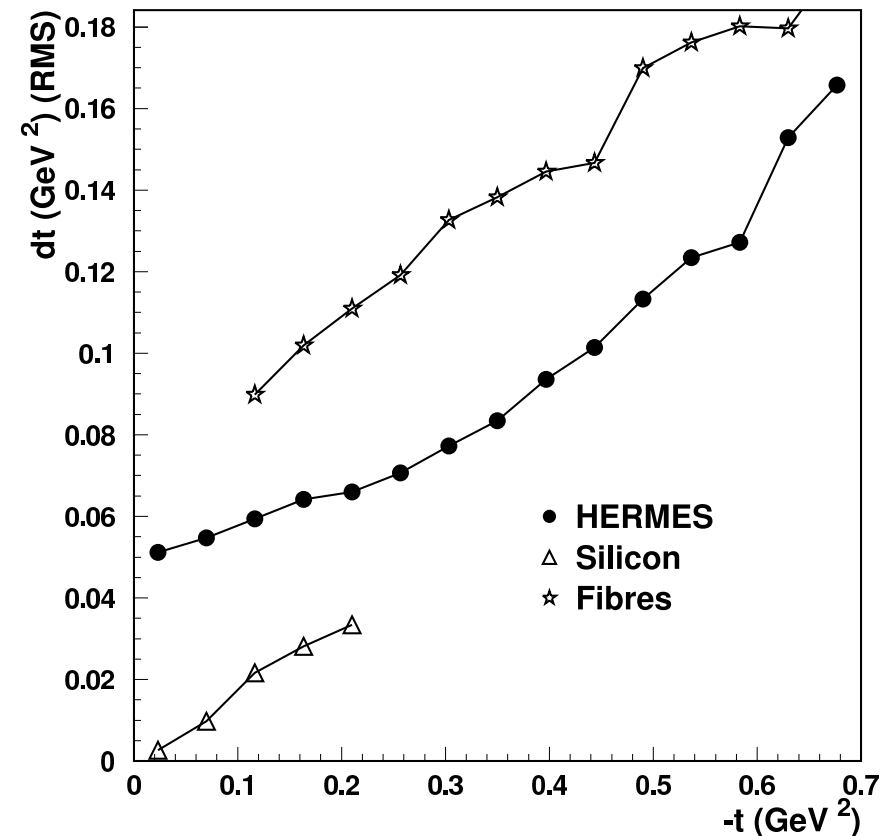

HERMES Recoil Detector Goals II & Status

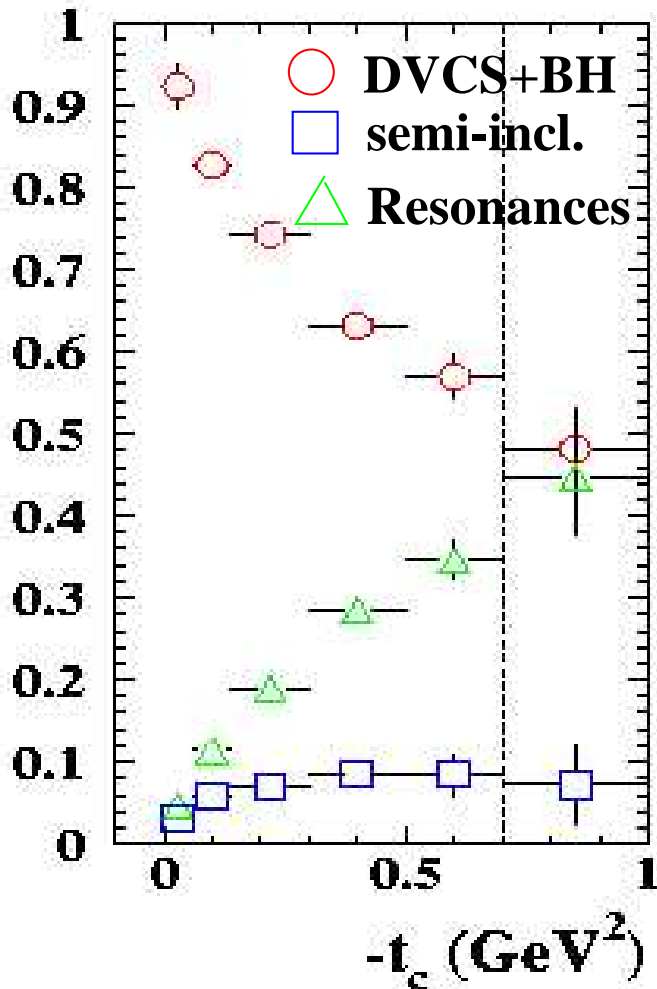

(Performance improvements shown for DVCS)

- Enhance signal fraction
- Reduce background contributions
 - semi-incl.: 5% \rightarrow \ll 1%,
 - associated prod.: 11% \rightarrow \sim 1%

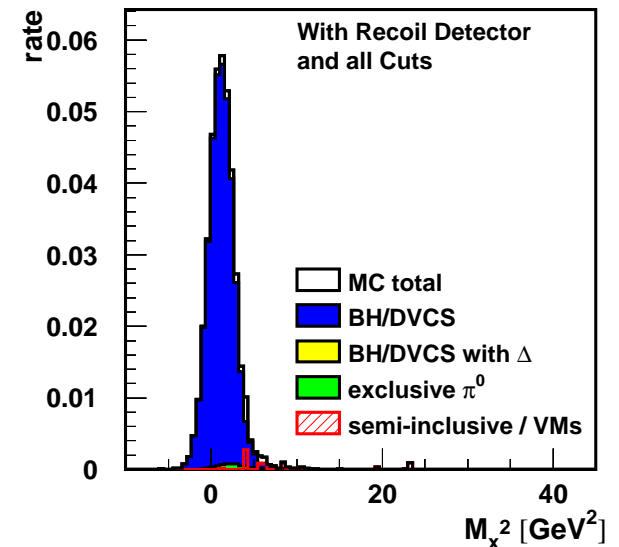
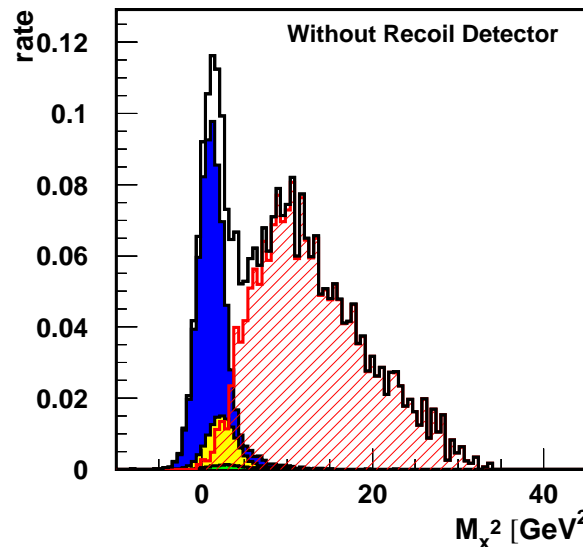

Status:

- Detector components ok, final calibration & alignment ongoing
- Tracking & connection to forward spectrometer being set up

Deeply Virtual Compton Scattering

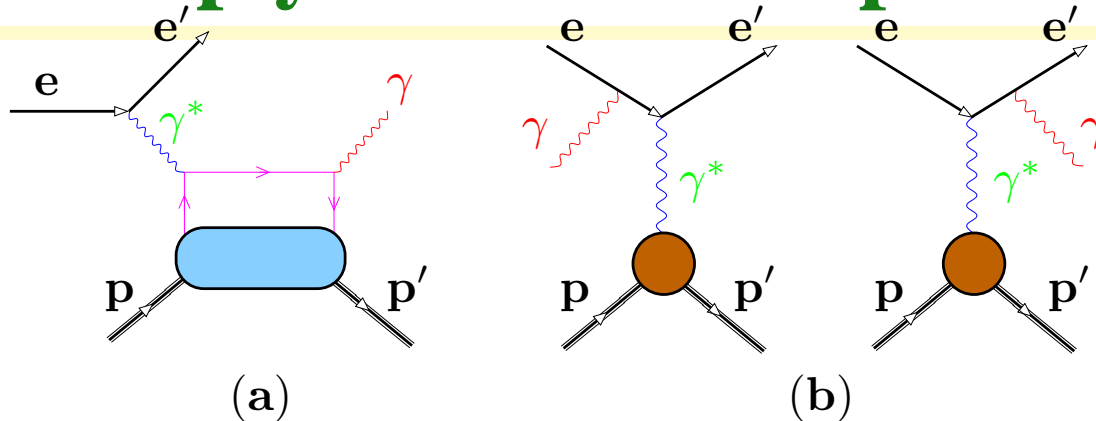

- Same final state in **DVCS** and **Bethe-Heitler** \Rightarrow **Interference!**

$$d\sigma(eN \rightarrow eN\gamma) \propto |\mathcal{T}_{BH}|^2 + |\mathcal{T}_{DVCS}|^2 + \underbrace{\mathcal{T}_{BH}\mathcal{T}_{DVCS}^* + \mathcal{T}_{BH}^*\mathcal{T}_{DVCS}}_{\mathcal{I}}$$

- \mathcal{T}_{BH} is parameterized in terms of **Dirac and Pauli Form Factors** F_1, F_2 , calculable in QED.
 - \mathcal{T}_{DVCS} is parameterized in terms of **Compton form factors** $\mathcal{H}, \mathcal{E}, \tilde{\mathcal{H}}, \tilde{\mathcal{E}}$ (which are convolutions of resp. **GPDs** $H, E, \tilde{H}, \tilde{E}$)
 - (Certain Parts of) interference term can be filtered out by forming certain **cross section** differences (or **asymmetries**)
- \Rightarrow **GPDs** $H, E, \tilde{H}, \tilde{E}$ indirectly accessible via **interference term** \mathcal{I}

Azimuthal Asymmetries in DVCS

DVCS–Bethe-Heitler Interference term \mathcal{I}

induces azimuthal asymmetries in cross-section:

- Beam-charge asymmetry $A_C(\phi)$ [BCA]

$$d\sigma(e^+, \phi) - d\sigma(e^-, \phi) \propto \text{Re}[F_1 \mathcal{H}] \cdot \cos \phi$$

- Beam-spin asymmetry $A_{LU}(\phi)$ [BSA]

$$d\sigma(\vec{e}, \phi) - d\sigma(\overleftarrow{e}, \phi) \propto \text{Im}[F_1 \mathcal{H}] \cdot \sin \phi$$

- Long. target-spin asymmetry $A_{UL}(\phi)$

$$d\sigma(\overleftarrow{P}, \phi) - d\sigma(\overrightarrow{P}, \phi) \propto \text{Im}[F_1 \tilde{\mathcal{H}}] \cdot \sin \phi \quad \text{[LTSA]}$$

- Transverse target-spin asymmetry $A_{UT}(\phi, \phi_s)$ [TTSA]:

$$d\sigma(\phi, \phi_s) - d\sigma(\phi, \phi_s + \pi) \propto \text{Im}[F_2 \mathcal{H} - F_1 \mathcal{E}] \cdot \sin(\phi - \phi_s) \cos \phi \\ + \text{Im}[F_2 \tilde{\mathcal{H}} - F_1 \xi \tilde{\mathcal{E}}] \cdot \cos(\phi - \phi_s) \sin \phi$$

(F_1, F_2 are the Dirac and Pauli elastic nucleon form factors)

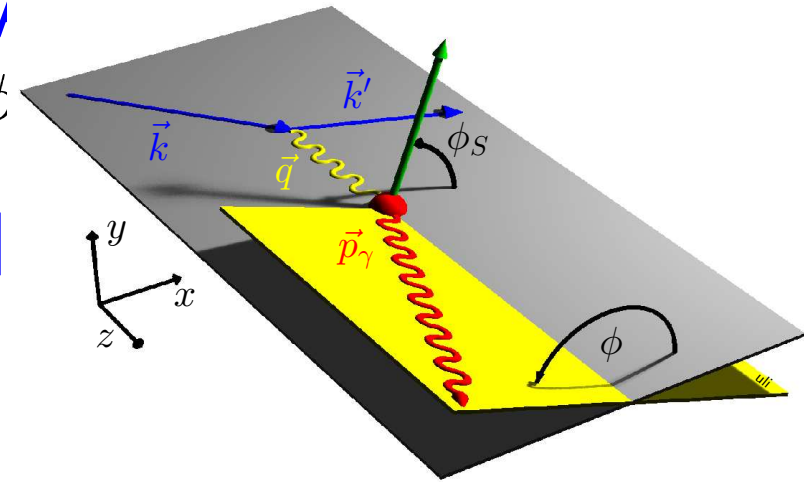

Exclusive DVCS Events at HERMES

REACTION : $e + p(d) \rightarrow e + \gamma (+X)$

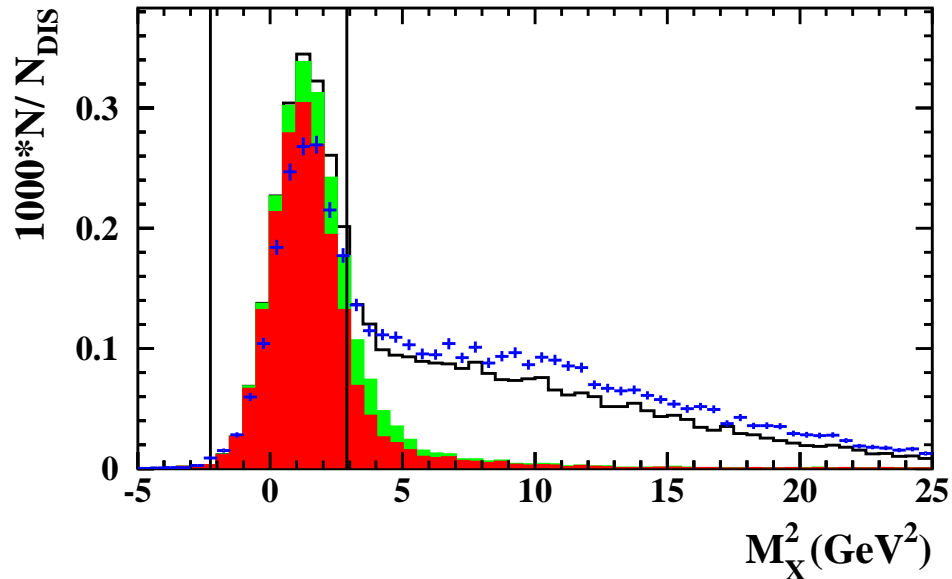

$$5 < \theta_{\gamma^* \gamma} < 45 \text{ mrad}$$

$$-t < 0.7 \text{ GeV}$$

$$0.03 < x_B < 0.35$$

$$1 < Q^2 < 10 \text{ GeV}^2$$

$$W > 3 \text{ GeV}$$

$$\nu < 22 \text{ GeV}$$

$$-(1.5)^2 < M_X^2 < (1.7)^2 \text{ GeV}$$

- absolute normalization of data and Monte Carlo [solid line]
- elastic Bethe-Heitler process is main contribution in signal region
- associated Bethe-Heitler process is a small contribution
- semi-inclusive production is main background at higher M_X^2
- as recoiling proton not (yet) detected, missing mass cut used instead
- t calculated under assumption of exclusivity, via scattered lepton kinematics

HERMES Data Taking DVCS Statistics (in pb⁻¹)

HERA-I (1996-2000)	H	D	⁴ He	N ₂	Ne	Kr
BSA/BCA e ⁻	11	50	-	-	-	-
BSA/BCA e ⁺	240	320	30	50	86	30
contains LTSA (e ⁺)	50	170				

HERA-II (2002-2007)	H	TTSA (H)	D	Kr	Xe	H ^{rec.}	D ^{rec.}	
BSA/BCA e ⁻	250	(<i>BCA</i> :10) <i>pub</i>	85	150	50	50	t.b.d.	t.b.d.
BSA/BCA e ⁺	820	60	200	55	30	750	200	

- Beam polarization $\langle P_{beam} \rangle$: only $\geq 30\%$ for HERA-II (while $\geq 50\%$ for HERA-I !)
- 2006-2007 running will more than double statistics on UNpolarized H target (23M \rightarrow 56M DIS events for BSA, huge improvement for *BCA*)
- No e⁻ data set, i.e. no *BCA with Recoil detector* due to target cell accident
- Recoil Detector in projected shape since start of e⁺ running middle 2006

HERMES Beam-charge Asymmetry vs. ϕ and M_X^2

$$A_C(\phi) = \frac{d\sigma^+(\phi) - d\sigma^-(\phi)}{d\sigma^+(\phi) + d\sigma^-(\phi)} \propto \text{Im}F_1 \mathcal{H} \cdot \cos \phi$$

\Rightarrow extract 'amplitudes' by fitting in every ϕ -bin

$$A_C(\phi) = \text{const.} + A_C^{\cos \phi} \cos \phi + A_C^{\cos 2\phi} \cos 2\phi + A_C^{\cos 3\phi} \cos 3\phi$$

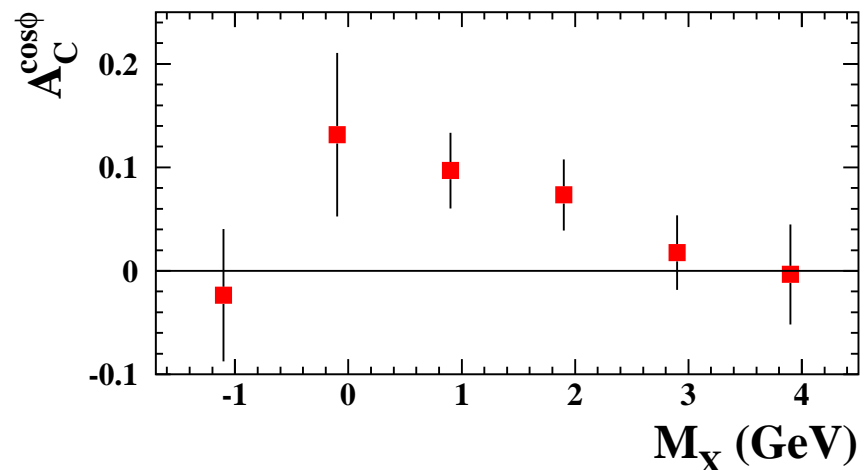
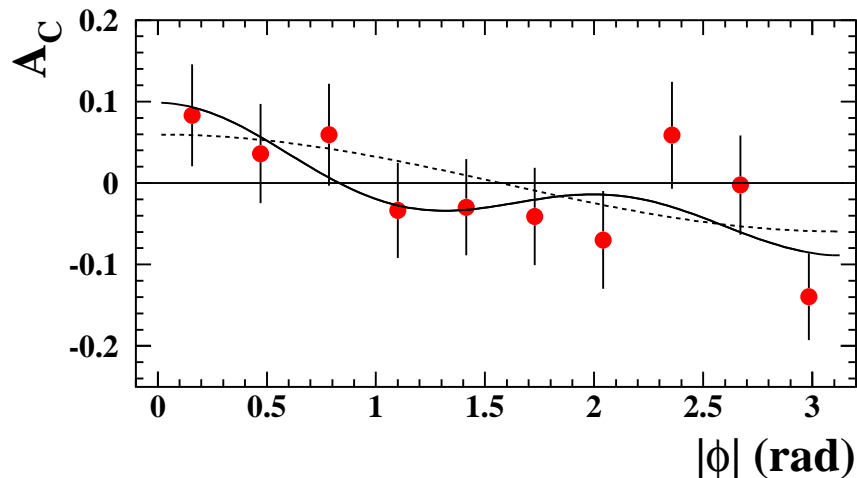

- published results shown for **unpolarized proton** target [hep-ex/0605108, PRD75(2007)01110]
- use *symmetrization* ($\phi \rightarrow |\phi|$) to get rid of sinusoidal terms
- $A_C^{\cos \phi} = 0.060 \pm 0.027$, other contributions insignificant (dashed = pure $\cos \phi$)
- asymmetry only in exclusive and 'associate' M_X^2 region (\rightarrow resol. smearing)
- preliminary deuteron data (not shown) completely consistent

HERMES Beam-charge Asymmetry vs. t

BCA t -dependence can distinguish different GPD model versions:

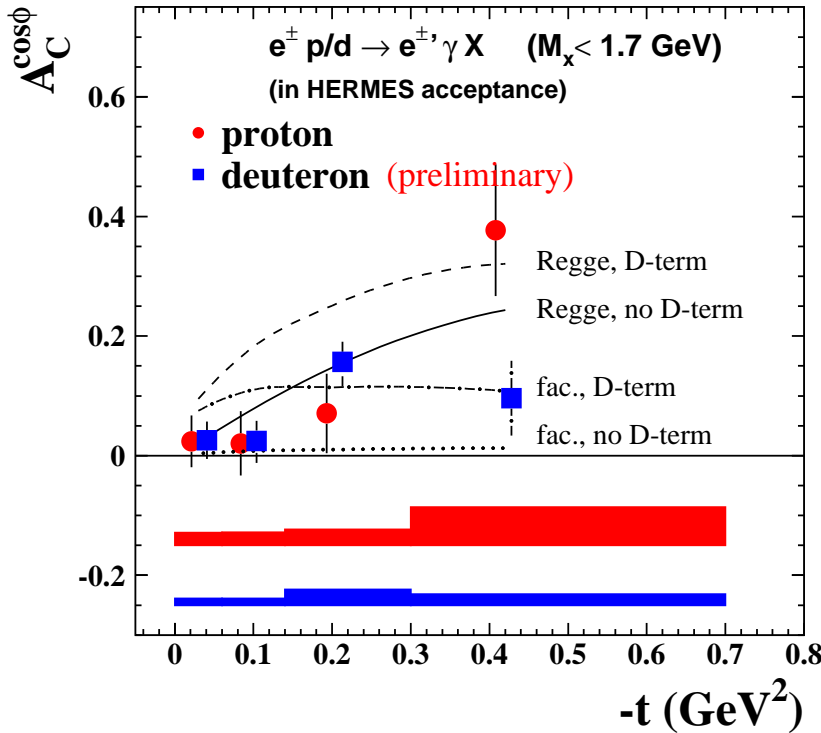

- $A_C^{\cos\phi}$: elastic + associated production
- d-data: contributions per t -bin of associated production: 5,11,18,29% \Rightarrow highest t -bin mostly affected
- GPD H dominates, \tilde{H} and E suppressed [Goeke, Polyakov, Vanderhaeghen, PPNP 47(2001)401]
- Curves (code [Vanderhaeghen, Guichon, Guidal]) calculated for 4 different parameter sets
- BCA insensitive to profile fct. parameters

- already HERA-I data disfavor Regge-inspired t -dependence with D-term
- more precise BCA data from HERA-II (to be analyzed)
- reduction of background & associated contribution by recoil detector: expected for e^+ sample, but no e^- sample with recoil (can one rely on 'similarity' cuts ??)

CLAS & HERMES: early Beam-spin Asymmetries

$$A_{LU}(\phi) = \frac{1}{\langle |P_B| \rangle} \cdot \frac{d\sigma^{\rightarrow}(\phi) - d\sigma^{\leftarrow}(\phi)}{d\sigma^{\rightarrow}(\phi) + d\sigma^{\leftarrow}(\phi)} \propto \text{Im}F_1 \mathcal{H} \cdot \sin \phi$$

⇒ extract 'amplitudes' fitting per ϕ -bin $A_{LU}(\phi) = c + A_{LU}^{\sin \phi} \sin \phi + A_{LU}^{\sin 2\phi} \sin 2\phi$

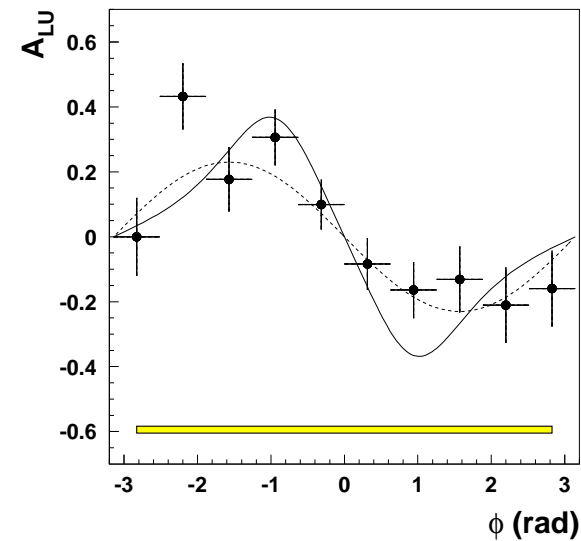
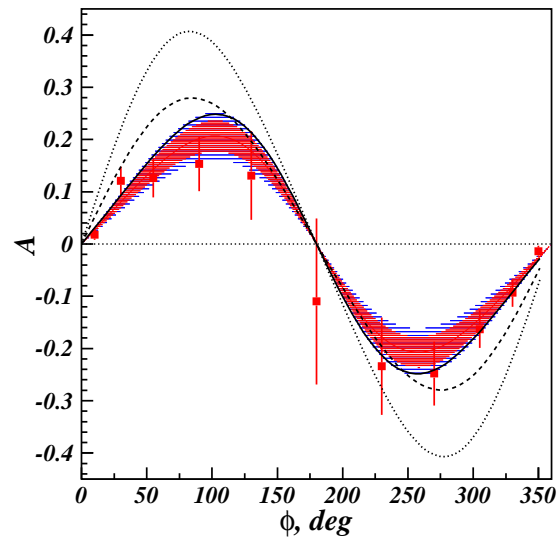

- HERMES: 27.5 GeV p , $P_B \approx 55\%$. Recoil proton not detected [PRL87(2001,1820)]
- CLAS: 4.25 GeV p , $P_B \approx 70\%$. Produced gamma not detected [PRL87(2001,1820)]
- expected $\sin \phi$ behaviour: significant $\sin \phi$ amplitudes on both targets
- other harmonics don't contribute significantly

BSA and BCA 2000-2007 HERMES Projections

HERMES hep-ex/0605108 ▲ HERMES PRL 2001 (96/97 data)

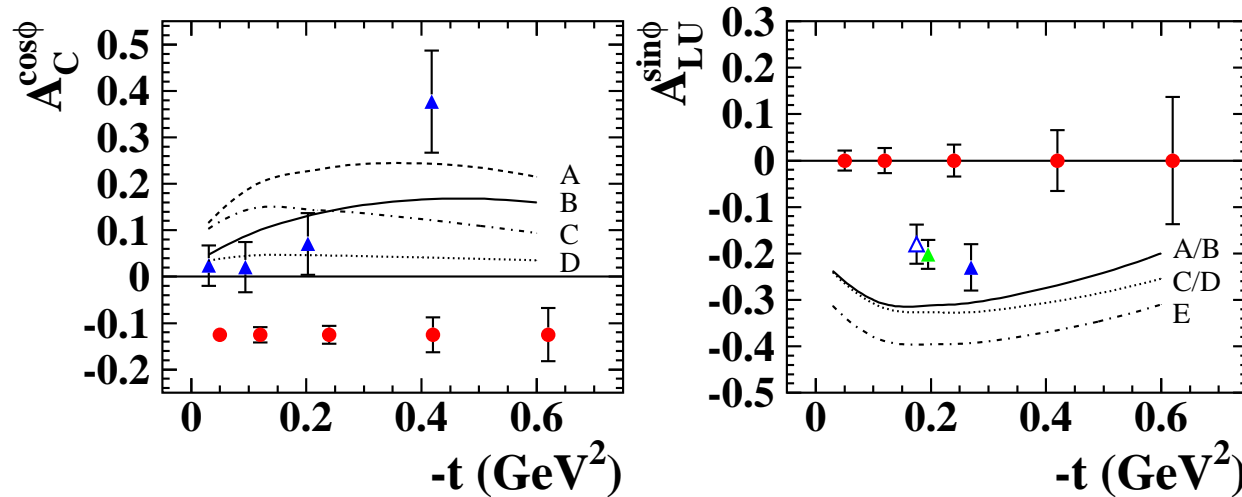

PROTON TARGET:

- △ HERMES hep-ex/0212019 (2000 data)
- ▲ CLAS PRL 2001
- HERMES 2002-2007 proj. (1 fb⁻¹ e⁺, 0.25 fb⁻¹ e⁻)

● 1996-2000: $P_B \approx 55\%$, 2002-2007: $P_B \approx 35\%$

● existing GPD model versions well distinguishable via t -dependence

● statistics marginal for 2-dimensional dependences

● reduced fraction of associated production by including Recoil Detector, but:

- statistics lower by about factor 1.4 (efficiency)

- ok for BSA, no BCA (no e⁻ recoil data)

⇒ model comparison possible over *full* measured t -range (at least for BSA)

CLAS E01-113: High-stat. Beam-spin Asymmetry

- 1st dedicated Hall-B DVCS exp't: 5.76 GeV e^- beam, pol. 76-82%; unpol. LH₂
- CLAS spectrometer upgraded by inner calorimeter to detect γ 's at small angles
→ all 3 final state particles ($e' N \gamma$) detected!
- Broad kinematic coverage at medium x (0.1...0.5), combined with high lumi
→ 3-dim. binning possible. Unpublished (White Paper) preview:

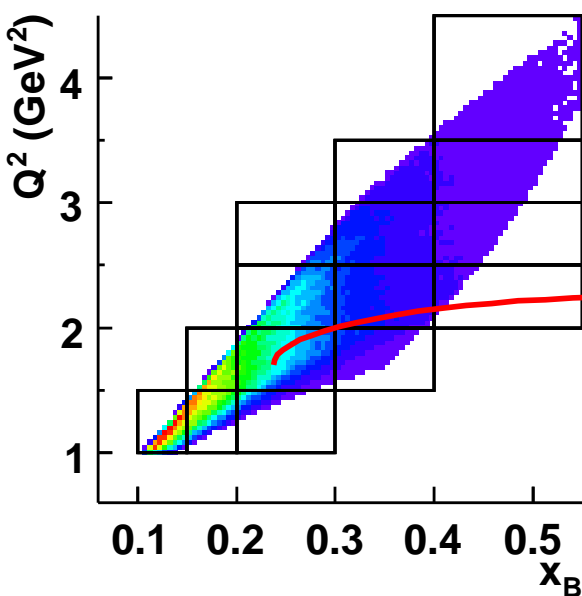

One single (x_B, Q^2) bin

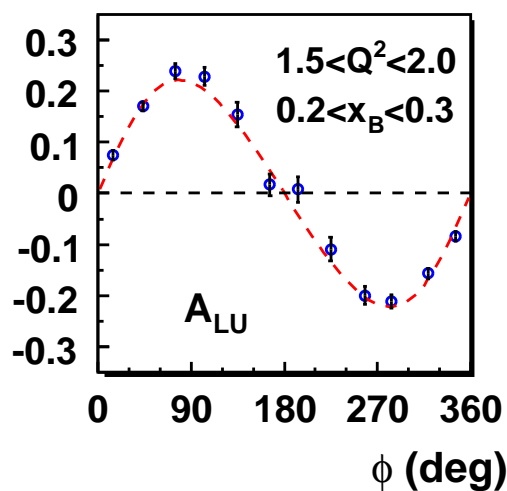

One (x_B, Q^2, t) bin out of five

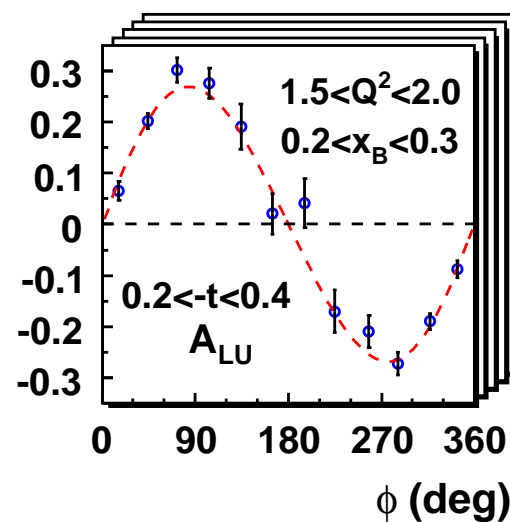

⇒ Very promising first glimpse into statistical power of JLab DVCS measurements

JLab E00-110 Scaling Test of DVCS Cross Section

- 5.75 GeV e^- beam (76% pol.), unpol. LH₂ target, [PRL 97 (2006) 262002]
- Detect e' by HRS, γ by EM calorimeter, recoil p by scintillator array
- 3 different kinematic settings with $x_{Bj} = 0.36$ fixed:
 $Q^2 = 1.5, 1.9, 2.3$ GeV². For each: $-t = 0.17, 0.23, 0.28, 0.33$ GeV
- Measured separately: $\frac{d^4\Sigma}{d^4\Phi} = \frac{1}{2} \left[\frac{d^4\sigma^+}{d^4\Phi} - \frac{d^4\sigma^-}{d^4\Phi} \right]$ and $\frac{d^4\sigma}{d^4\Phi} = \frac{1}{2} \left[\frac{d^4\sigma^+}{d^4\Phi} + \frac{d^4\sigma^-}{d^4\Phi} \right]$

⇒ distinct information on GPDs:

$\frac{d^4\sigma}{d^4\Phi} \propto \text{Re } \mathcal{I}$: same as in BCA

$\frac{d^4\Sigma}{d^4\Phi} \propto \text{Im } \mathcal{I}$: as in BSA numer.

- Fit following terms separately:

$|BH^2|$ (dot-dot-dashed),
 twist-2 int. term (dashed),
 twist-3 int. term (dot-dashed)
 ($|DVCS|^2$ found below few %)

- Twist-3 terms small

- $\frac{d^4\sigma}{d^4\Phi} \gg |BH^2| \rightarrow$ (relative) BSA should not be directly identified with $\text{Im } \mathcal{I}$!

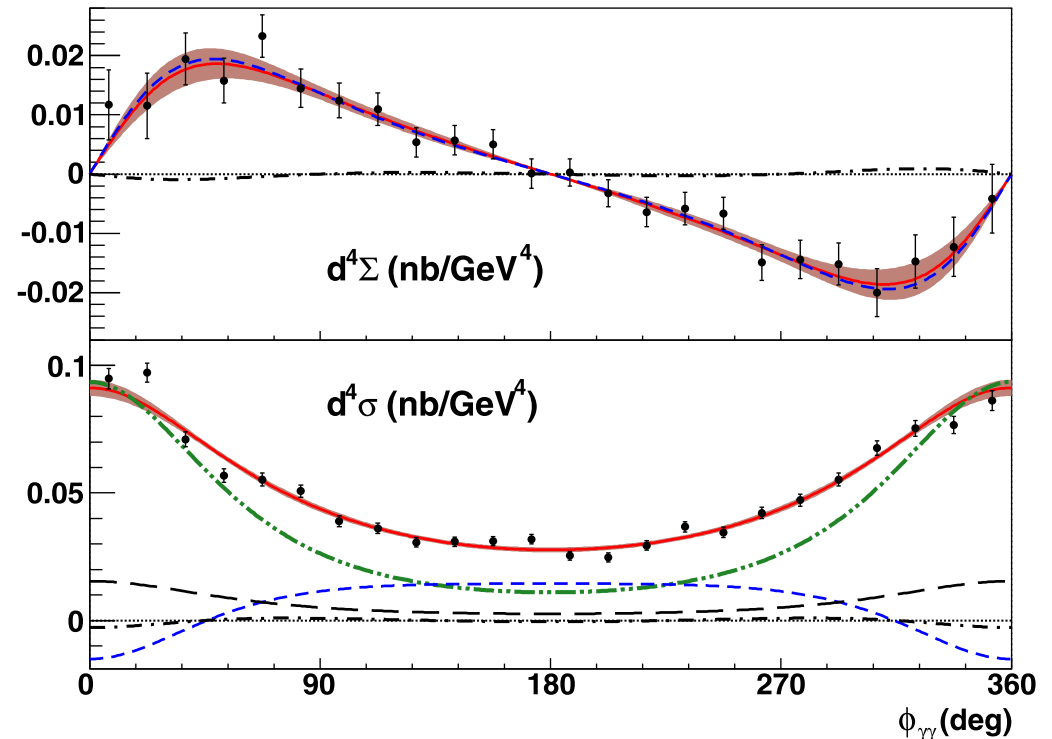

DVCS on Nuclear Targets

INCOHERENT PRODUCTION:

- nucleus breaks up & scattering occurs on **single nucleon**
- neutron e.m. form factor is small for small & medium t
 - BH neutron cross section small, hence also the interference term I
 - **asymmetry in incoherent nuclear DVCS similar to that on the proton**

COHERENT PRODUCTION:

- scattering occurs on the **whole nucleus**
 - **coherent nuclear DVCS proceeds preferentially at very low t**
 - **obtain enriched samples by 'separation cut' at $t = 0.03...0.05 \text{ GeV}^2$**

GPD-based MODELS:

- describe modifications of parton-parton correlations in nuclear environment
 - **dynamical interplay within highly complex bound hadronic systems ?**
- tool to compare to theory predictions: $\frac{A_{LU}^{nucleus}}{A_{LU}^{proton}}$ (generalized EMC effect)

HERMES Nuclear DVCS: Beam-spin Asymmetry

- Targets: ^2H , ^4He , ^{14}N , ^{20}Ne , $^{82-86}\text{Kr}$, $^{129-134}\text{Xe}$
- Clear $\sin\phi$ amplitudes seen in exclusive region

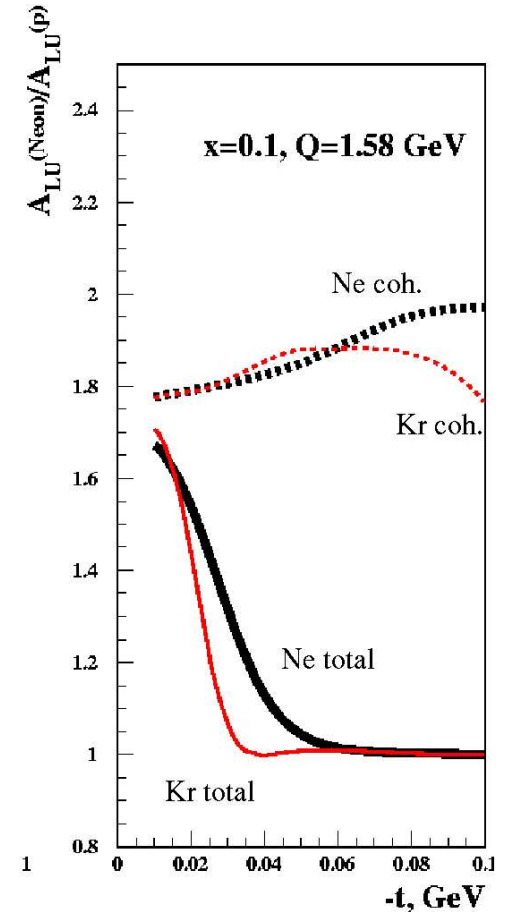
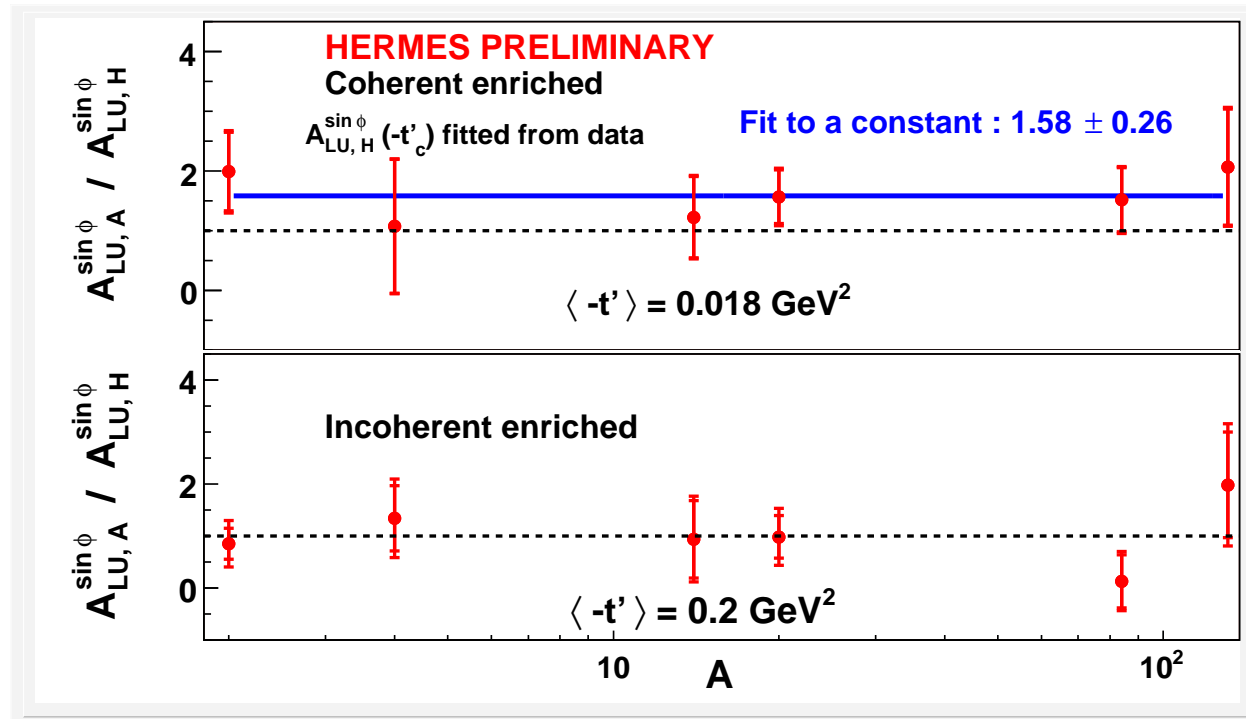

- Model predictions by Guzey&Strikhman [PRC68(2003)015204]: $\uparrow\downarrow\uparrow\downarrow$
- Coherent-enriched region ($\langle -t \rangle = 0.018 \text{ GeV}^2$): $BSA(A)/BSA(p) \approx 1.8$
- Incoherent-enriched region ($\langle -t \rangle = 0.2 \text{ GeV}^2$): $BSA(A)/BSA(p) \approx 1$

⇒ good agreement with model predictions

HERMES Long. Target-spin Asymmetry vs. ϕ

$$A_{UL}(\phi) = \frac{1}{\langle |P_L| \rangle} \cdot \frac{d\sigma^{\rightarrow}(\phi) - d\sigma^{\leftarrow}(\phi)}{d\sigma^{\rightarrow}(\phi) + d\sigma^{\leftarrow}(\phi)} \propto \text{Im} F_1 \tilde{\mathcal{H}} \sin \phi$$

⇒ extract 'amplitudes' fitting per ϕ -bin $A_{UL}(\phi) = c + A_{UL}^{\sin \phi} \sin \phi + A_{UL}^{\sin 2\phi} \sin 2\phi$

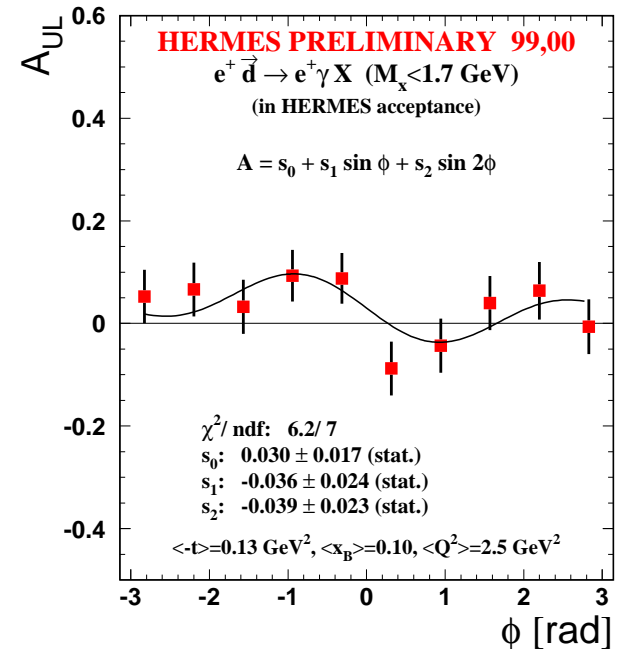
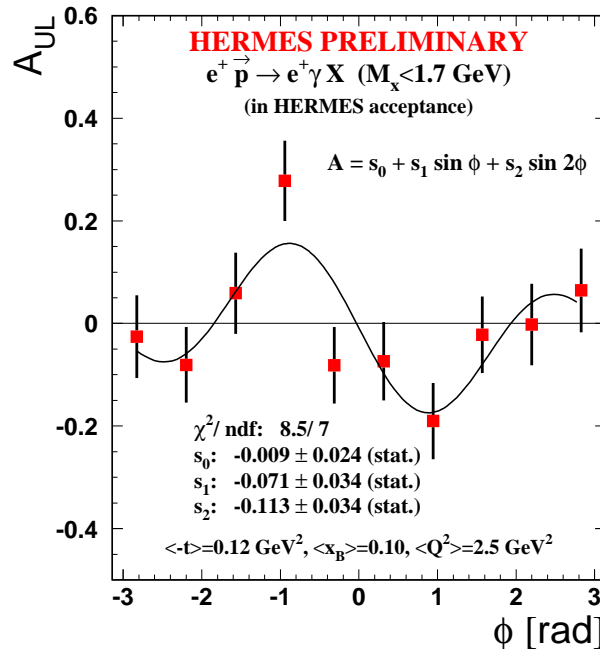

- FULL existing data set analyzed (1996-2000 data)
- expected $\sin \phi$ behaviour : 2σ (1.5σ) on proton (deuteron)
- unexpected, sizeable ($> 3\sigma$) $A_{UL}^{\sin 2\phi}$ on proton (1.7σ on deuteron) ⇒ twist-3 ?
 (π^0 background found to be responsible for *at most* a small fraction of it)

HERMES Long. Target-Spin Asymmetry vs. t

- Twist-3 GPDs: WW-term + interaction-dep. (qGq) term: $F^3 = F_{WW}^3 + F_{qGq}^3$
- Existing models include only WW-terms of twist-3 GPDs

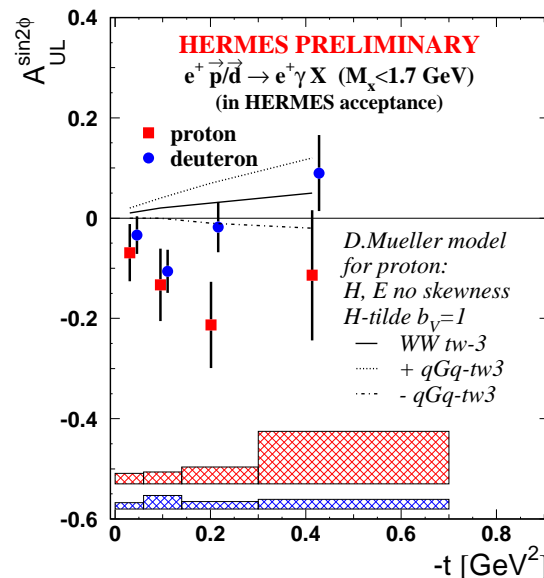
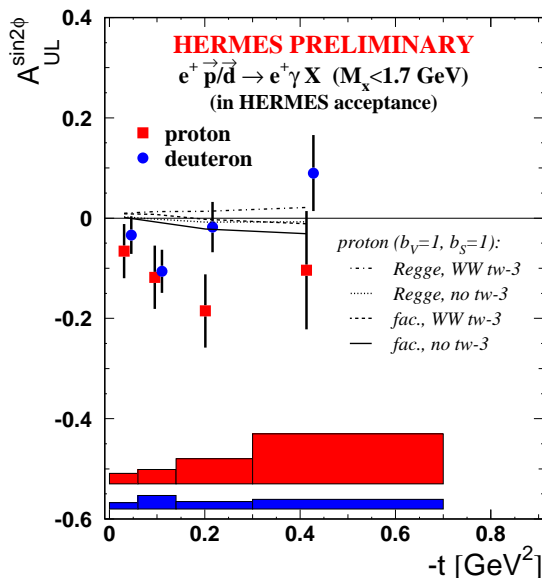
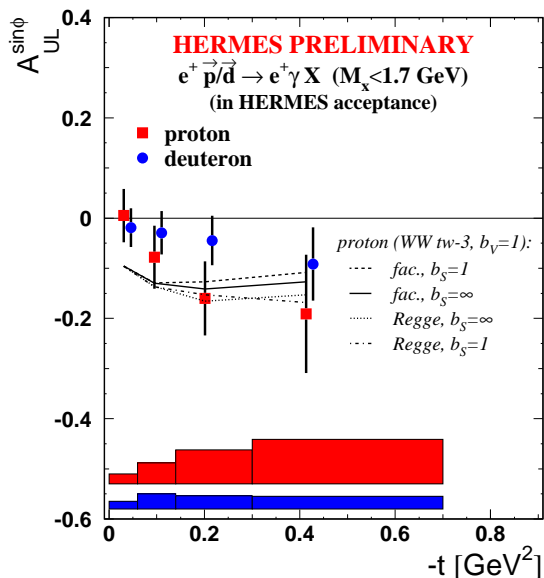

- Lowest t -bin: No effect from coherent prod. on deuteron (40% of statistics)
- higher t : $A_{UL}(ep) \neq A_{UL}(ed) \Rightarrow A_{UL}(ep) \neq A_{UL}(en)$
- Only Proton models exist: \rightarrow for $A_{UL}^{\sin \phi}$; VGG model does ok.
 \rightarrow for $A_{UL}^{\sin 2\phi}$: ● VGG (twist-3 only WW) fails completely
 ● D.Müller [priv.comm.]: Upper limits for qGq (dynamic) twist-3 corrections

CLAS Longitudinal Target-spin Asymmetry

$$A_{UL}(\phi) \propto \text{Im}(\xi(F_1 + F_2)\mathcal{H} + F_1\tilde{\mathcal{H}}) \sin \phi$$

- JLab Hall-B (CLAS), E01-113, $^{15}\text{NH}_3$, 5.7 GeV [PRL 97 (2006) 072002]
- beam helicities averaged, target polarization 60-80%, dilution $f = 0.78$
- $\langle Q^2 \rangle = 1.82 \text{ GeV}^2$
 $\langle -t \rangle = 0.31 \text{ GeV}, \langle \xi \rangle = 0.16$

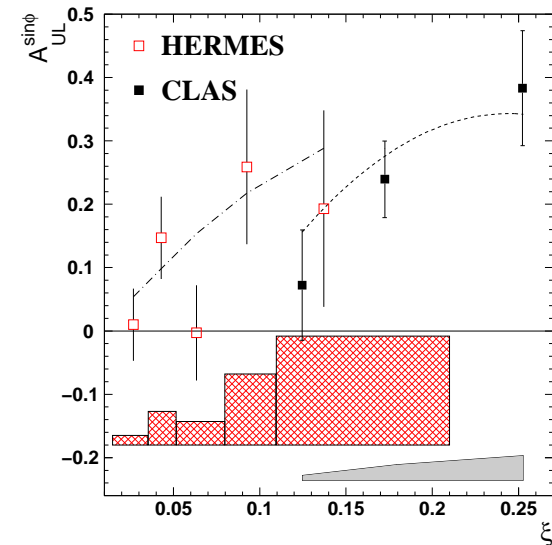
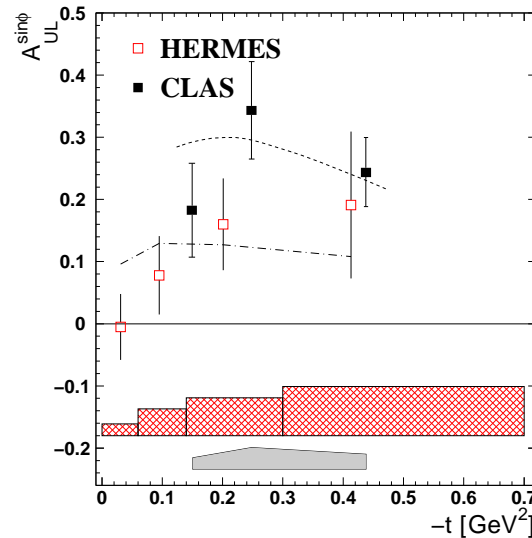
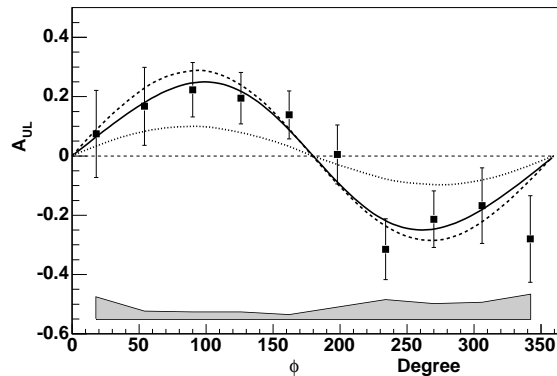

- Left panel: dashed: $E = \tilde{E} = 0$; dotted: also $\tilde{H} = 0$; line: fit. HERMES (right): Ph.D. M. Kopytin
- large $\sin 2\phi$ moment in π^0 background \Rightarrow bg subtracted/corrected
- expected $\sin \phi$ behaviour: $A_{UL}^{\sin \phi} = 0.252 \pm 0.042^{stat} \pm 0.020^{syst}$
- Higher twist negligible: $A_{UL}^{\sin 2\phi} = -0.022 \pm 0.045^{stat} \pm 0.021^{syst}$

Why TTSA Data Expected to be Sensitive to J_q ?

$$A_{UT}(\phi, \phi_S) \propto \text{Im}[F_2 \mathcal{H} - F_1 \mathcal{E}] \sin(\phi - \phi_S) \cos \phi + \text{Im}[F_2 \tilde{\mathcal{H}} - F_1 \xi \tilde{\mathcal{E}}] \cos(\phi - \phi_S) \sin \phi$$

ANSATZ: spin-flip Generalized Parton Distribution E can be parameterized as follows:

- Factorized ansatz for spin-flip quark GPDs: $E_q(x, \xi, t) = \frac{E_q(x, \xi)}{(1-t/0.71)^2}$
- t -indep. part via double distr. ansatz: $E_q(x, \xi) = E_q^{DD}(x, \xi) - \theta(\xi - |x|) D_q\left(\frac{x}{\xi}\right)$
- using double distr. K_q : $E_q^{DD}(x, \xi) = \int_{-1}^1 d\beta \int_{-1+|\beta|}^{1-|\beta|} d\alpha \delta(x - \beta - \alpha\xi) K_q(\beta, \alpha)$
- with $K_q(\beta, \alpha) = h(\beta, \alpha) e_q(\beta)$ and $e_q(x) = A_q q_{val}(x) + B_q \delta(x)$
based on chiral QSM
- where coeff.s A, B constrained by Ji relation, and $\int_{-1}^{+1} dx e_q(x) = \kappa_q$
- A_u, A_d, B_u, B_d are functions of J_u, J_d
 $\Rightarrow J_u, J_d$ are free parameters when calculating TTSA

DVCS TTSA: HERMES Data vs. Predictions

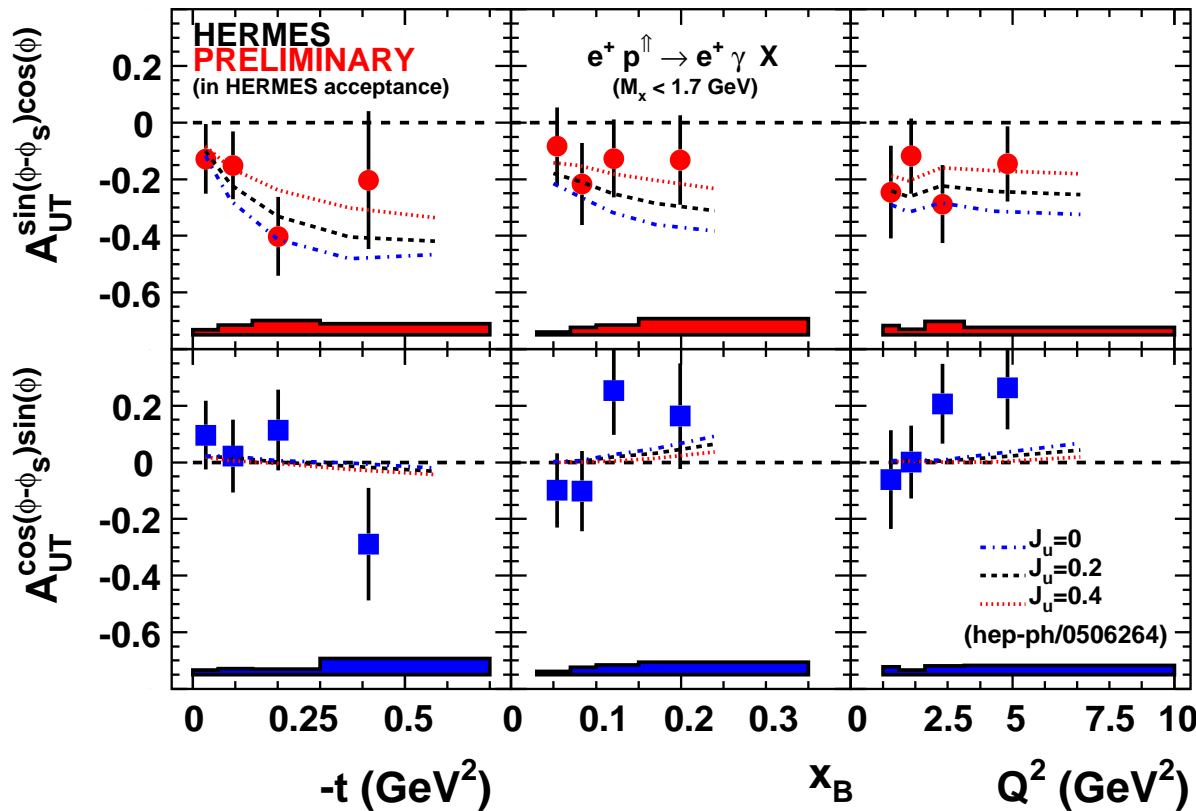

$$A_{UT}(\phi, \phi_S) = \frac{1}{\langle |P_T| \rangle}$$

$$\frac{d\sigma(\phi, \phi_S) - d\sigma(\phi, \phi_S + \pi)}{d\sigma(\phi, \phi_S) + d\sigma(\phi, \phi_S + \pi)} =$$

$$A_{UT}^{\sin(\phi - \phi_S) \cos \phi} \cdot \sin(\phi - \phi_S) \cos \phi$$

$$+ A_{UT}^{\cos(\phi - \phi_S) \sin \phi} \cdot \cos(\phi - \phi_S) \sin \phi$$

HERMES e^+p^{\uparrow} 2002-04:

- U: unpolarized beam
- T: transv. pol. target
- ca. 50% of total stat.
- [2004-05 data: e^-p^{\uparrow}]

STUDY sensitivity to J_u (with $J_d = 0$) [hep-ph/0506264, based on Prog.Part.Nucl.Phys.47]:

● $A_{UT}^{\sin(\phi - \phi_S) \cos \phi}$ found sensitive to J_u , while $A_{UT}^{\cos(\phi - \phi_S) \sin \phi}$ is not

● only weak sensitivity found to other GPD model parameters

(profile parameters, Regge/factorized ansatz for t -dependence)

HERMES: Model-dependent Constraint: J_u vs J_d

Unbinned maximum likelihood fit to $A_{UT}^{\sin(\phi-\phi_S)\cos\phi}$ at average kinematics (fitting prel. HERMES data against VGG-model based calculations), leaving J_u and J_d as free parameters \Rightarrow model-dependent 1- σ constraint on J_u vs. J_d :

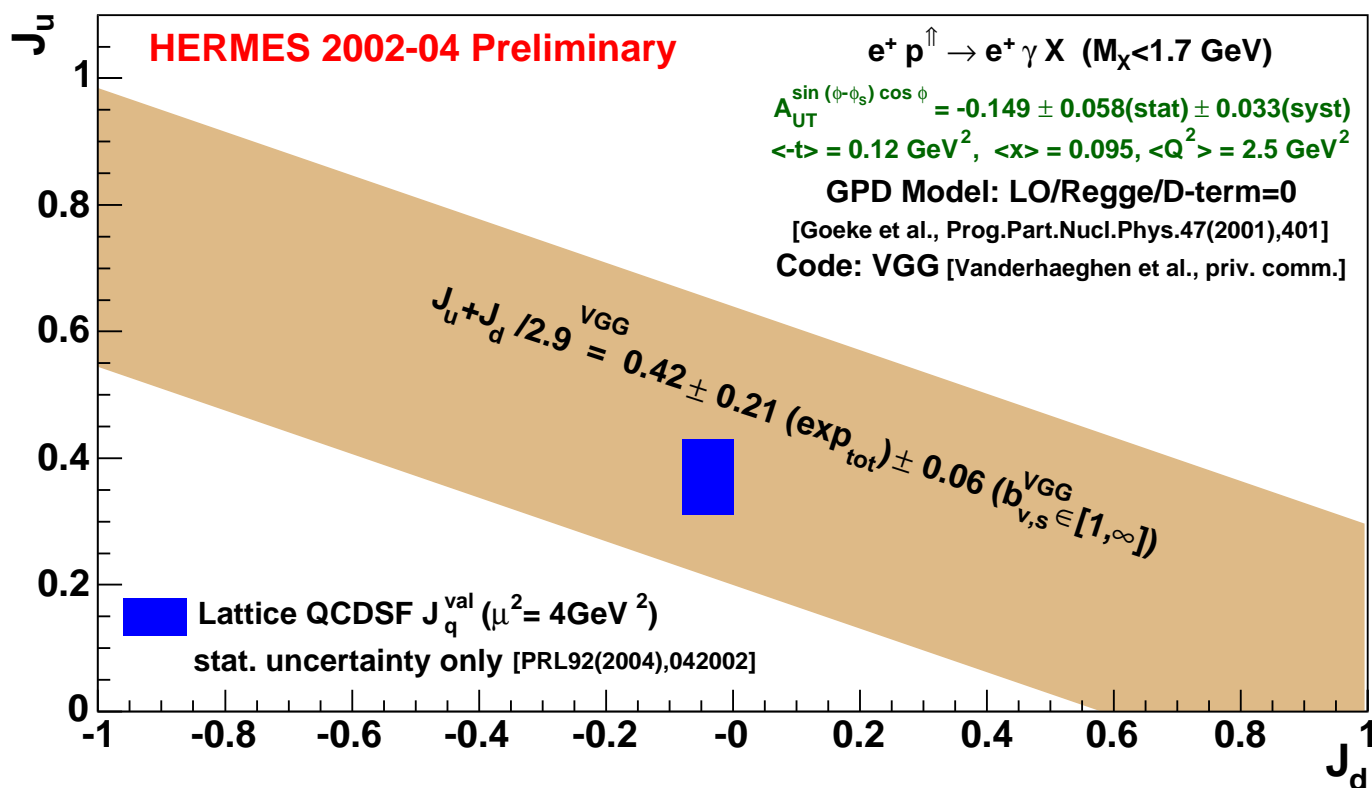

- Quenched **lattice calculation** done with pion masses 1070, 870, and 640 MeV, and then extrapolated linearly in m_π^2 to the physical value
- Uncertainties on VGG model parameters shown as separate uncertainty (± 0.06)

JLab E03-106: Neutron Beam-spin Asymmetry

$$A_{LU}(\phi) \propto \text{Im}[F_1(t)\mathcal{H} + \xi(F_1(t) + F_2(t))\tilde{\mathcal{H}} - \frac{t}{4M^2}F_2(t)\mathcal{E}] \sin \phi$$

- JLab Hall-A E03-106 (same set-up as E00-110): 5.75 GeV e^- beam, huge statistics (24000 fb⁻¹ !) on unpol. LD₂ target

- Advantage of neutron target: $F_1^n(t) \ll F_2^n(t)$

→ Contributions of H and \tilde{H} suppressed

→ can also access E !

- Unpublished (White Paper) projection → → → →

- Difficult to extract incoherent neutron information, because: coherent Deuteron + Neutron = Deuteron - proton

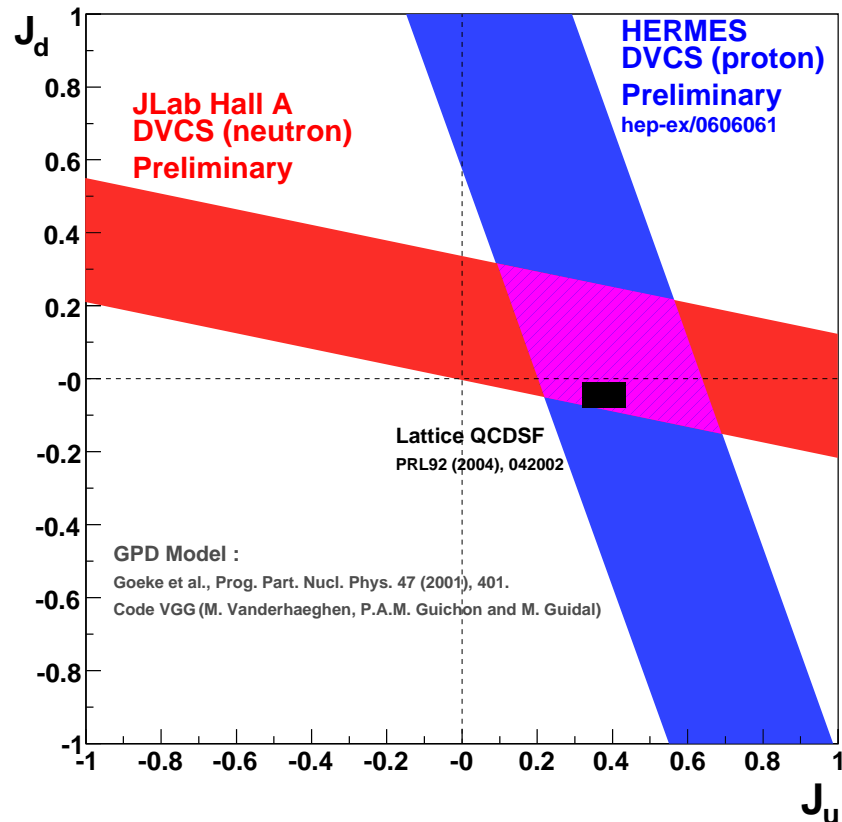

HERMES Exclusive π^+ Cross Section

- REACTION: $e p \rightarrow e \pi^+ n$ Access to polarized GPDs \tilde{H} and \tilde{E}
- $\sigma_{tot} = \sigma_T + \epsilon\sigma_L$; L/T separation at HERMES not possible ($0.80 < \epsilon < 0.96$)
- σ_T suppressed by $1/Q^2 \Rightarrow \sigma_L$ dominates at higher Q^2

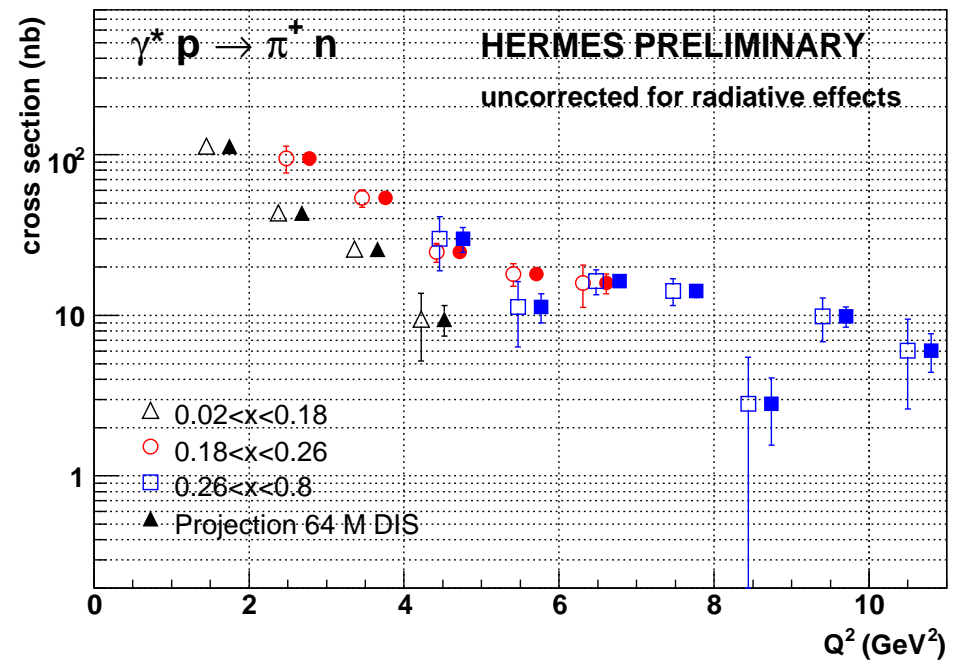
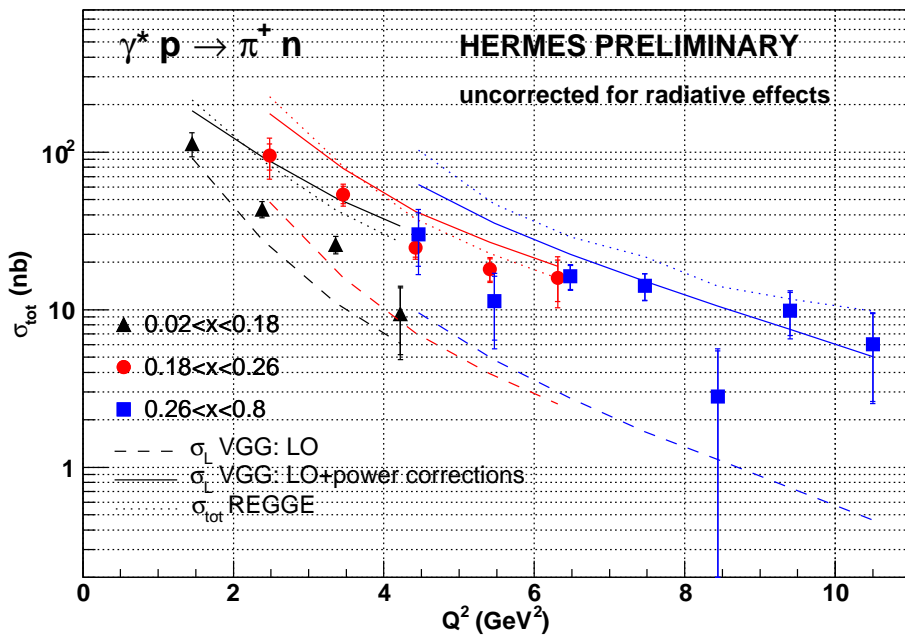

- VGG (LO+power corr.s) \approx Regge-based, BUT: data undershoot both models
- Factorization theorem $\rightarrow \sigma_L \propto 1/Q^6$: Kinematic $1/Q^4$ * Dynamic $1/Q^p$
- p fitted in the 3 x -bins: 1.9 ± 0.5 ; 1.7 ± 0.6 ; $1.5 \pm 1.0 \Rightarrow$ as expected

HERMES π^+ Transv. Target-spin Asymmetry

- Large $A_{UT}^{\sin \phi - \phi_S}$ predicted [Frankfurt et al., PRL 84(2000)2589]

from interference of pseudo-scalar (\tilde{H}) and pseudo-vector (\tilde{E}) amplitudes

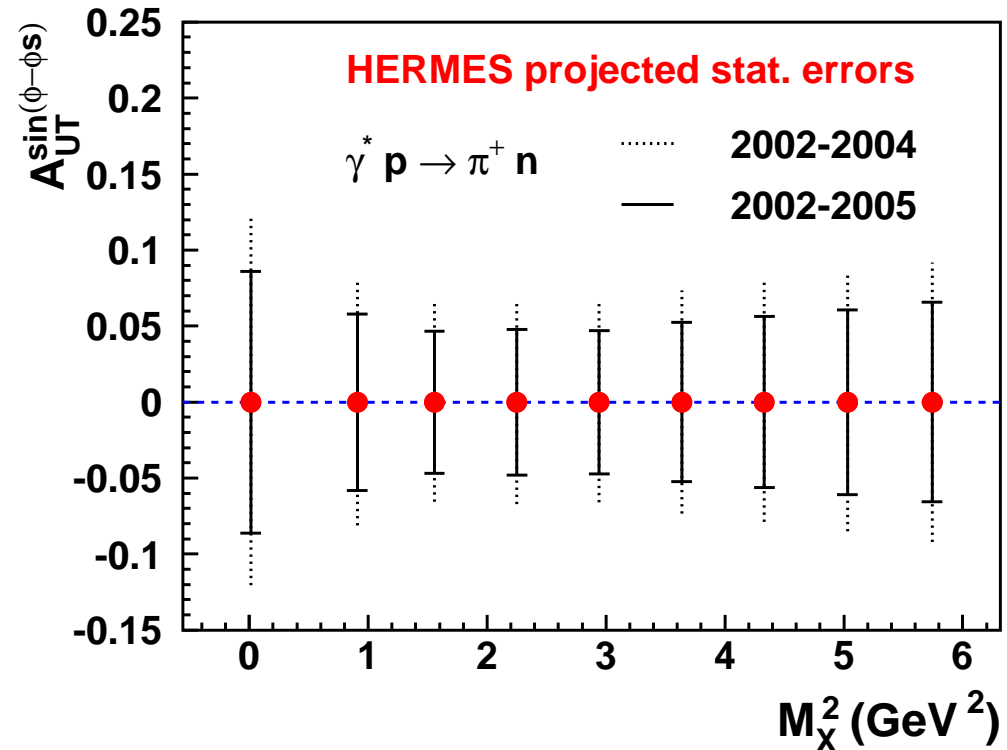
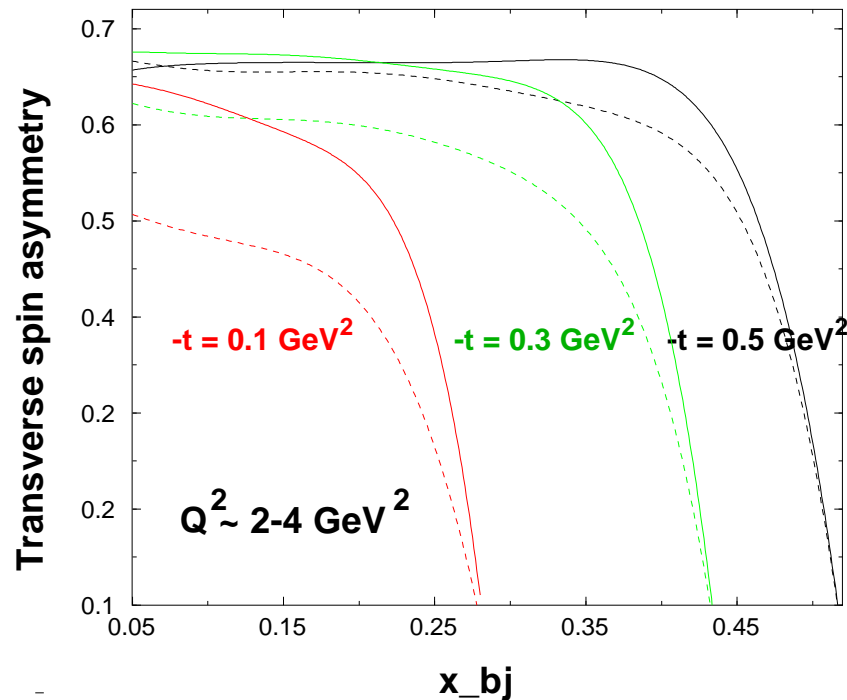

- background correction experimentally very difficult
- no released data available yet (PhD work going on)
- FULL data set (2002-2005): stat. errors may allow comparison with predictions

HERMES: Vector Meson Prod. on Unpol. Target

Photon-Nucleon CMS

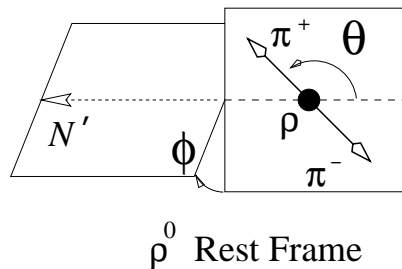
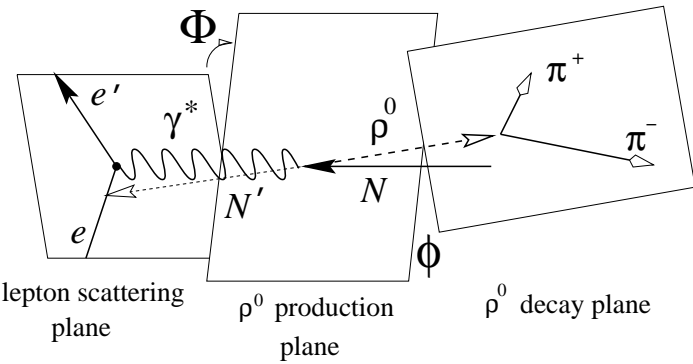

REACTION : $e + p(d) \rightarrow e + \rho^0 (+X)$

$$0.6 < M_{\pi^+\pi^-} < 1.0 \text{ GeV}$$

$$M_{K^+K^-} \geq 1.06 \text{ GeV}$$

$$-1.0 < \delta E < 0.6 \text{ GeV} \quad | \quad \text{diffr.}$$

$$-t' < 0.4 \text{ GeV} \quad | \quad \text{excl.}$$

$$1 < Q^2 < 5 \text{ GeV}^2$$

$$3 < W < 6.3 \text{ GeV}^2$$

$$y > 0.85$$

- SDMEs from maximum likelihood fit minimizing difference between:
 - 3-dimensional $(\cos \Theta, \phi, \Phi)$ decay angle matrix of data
 - fully reconstructed high statistics Monte Carlo set
- 1996-2000 data analyzed; polarized beam ($P_B \approx 0.53$), UNpolarized target
- 15 'unpolarized' ρ^0 SDMEs measured, precision comparable to H1/ZEUS
- 8 polarized ρ^0 SDMEs measured for the first time

HERMES SDMEs for ρ^0 and ϕ Vector Mesons

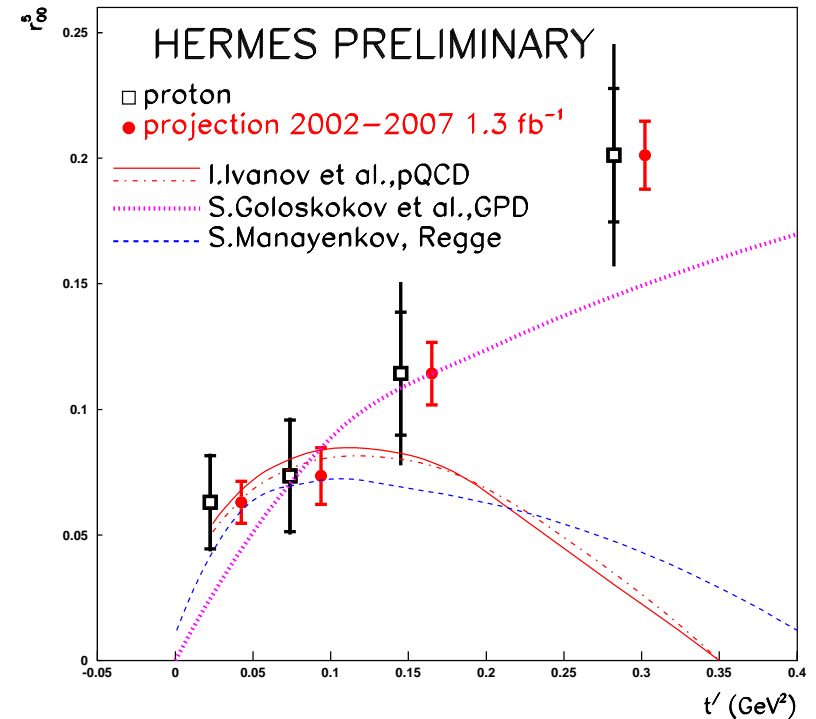
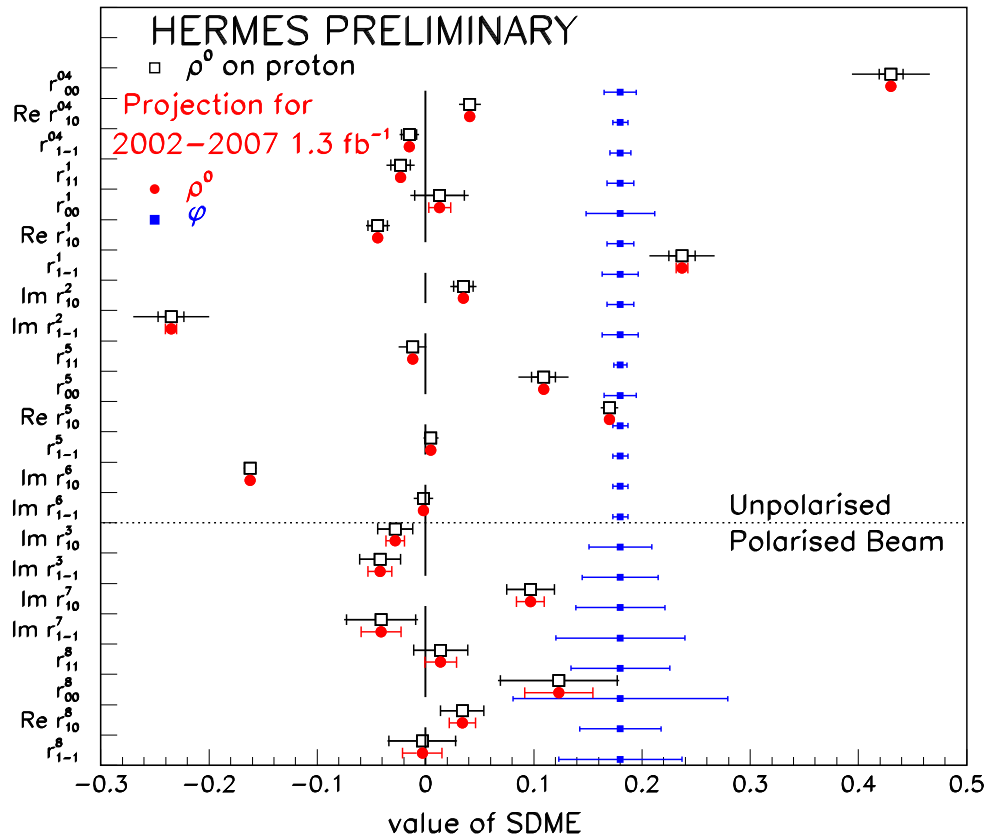

$$R = \frac{\sigma_L}{\sigma_T} \quad R^{SCHC} = \frac{1}{\epsilon} \frac{r_{04}^{00}}{1 - r_{04}^{00}} \quad R^{NPE} = \frac{1}{\epsilon} \left\{ \frac{1}{2r_{1-1}^1 - r_{00}^1} - 1 \right\} \quad \epsilon = \frac{1-y}{1-y+y^2/2}$$

- statistically significant violation of SCHC found
 - indication seen for existence of unnatural-parity-exchange amplitudes
- BOTH: ⇒ existence of 2-quark exchange at intermediate energies**

HERMES ρ^0 Spin-density-matrix Elements vs. t'

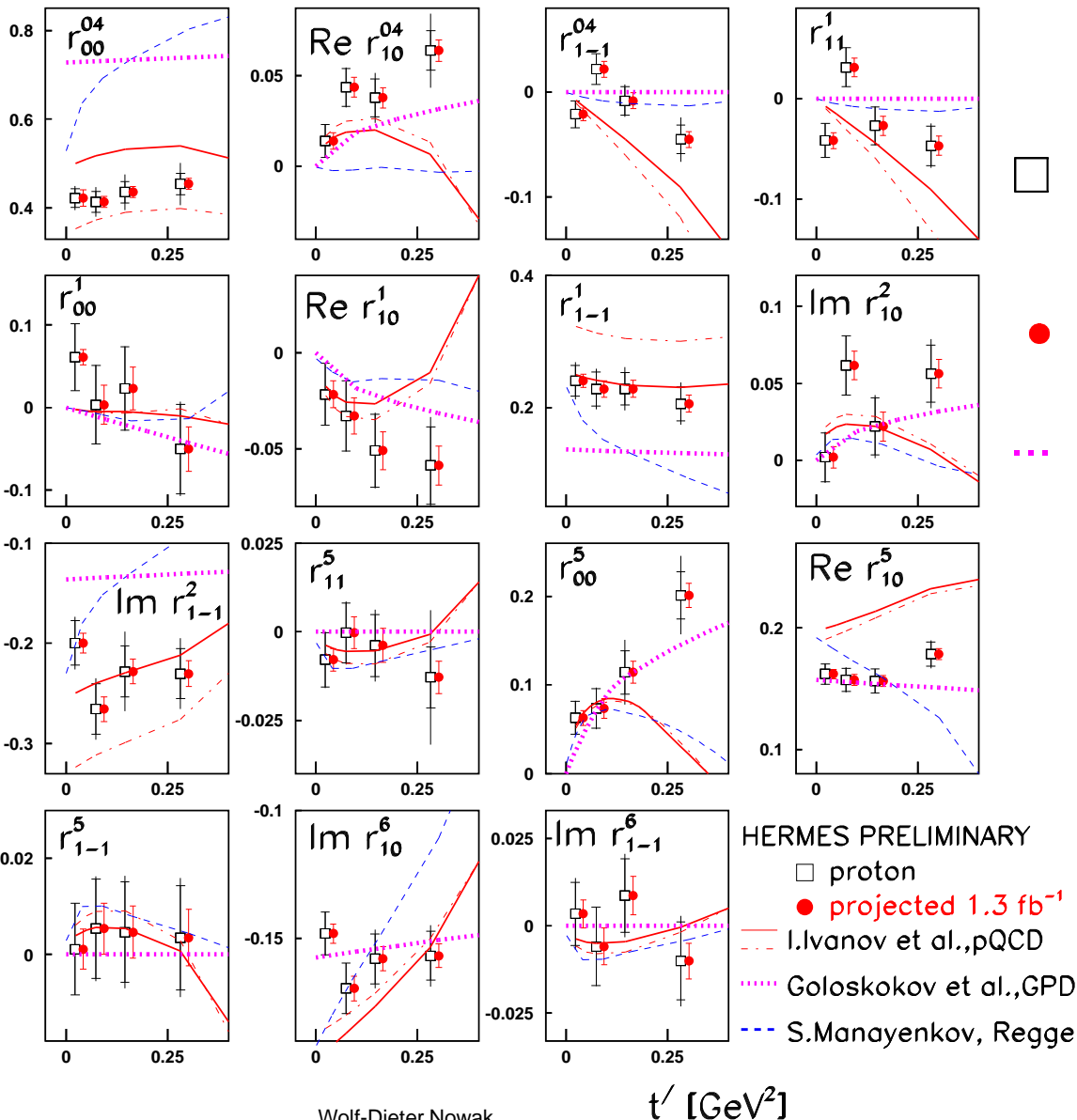

□ 15 'unpolarized' SDMEs from HERMES 1996-2000 proton data

● Projection 1996-2007 data

⋯ GPD-based model ($Q^2 > 3 \text{ GeV}^2$):
2-gluon exchange only

⇒ waiting for inclusion of quark-exchange into GPD-based model

(hoping for lower Q^2 -limit then)

Summary and Outlook

- ▶ The **HERMES** experiment played a **pioneering role** exploring the potential of exclusive photon/meson production towards an **interpretation of the data in terms of GPDs**. Azimuthal asymmetries were measured with respect to beam spin and charge, and to longitudinal and transverse target polarization. First constraints on GPD models were obtained, in particular a model-dependent **constraint on the u and d -quark total angular momenta**. The **HERMES RECOIL DETECTOR** is in full operation since summer 2006; the goal of $\approx 1 \text{ fb}^{-1}$ data will be reached by mid 2007, the end of HERA running.
- ▶ Hall-A **JLAB** DVCS cross section measurements suggest **twist-2 dominance** already at 6 GeV. As also by CLAS, many dedicated **high-statistics DVCS measurements** on various targets were/are/will be performed, which will have **strong impact on constraining GPDs**. Plans are being substantiated for measurements at 12 GeV that are hoped to become reality beyond 2012. Exclusive reactions will hence presumably be mapped in the next decade, allowing the construction of precise GPD models which are expected to describe the **3-dimensional structure of the nucleon**.