

Exclusive ρ^0 production with the Recoil Detector at HERMES & b-slopes

Avetik Airapetian, Michael Düren,
Roberto Pérez-Benito, Hasko Stenzel , Weilin Yu

II. Physikalisches Institut,
Justus-Liebig-Universität Gießen

On behalf the HERMES Collaboration
74. Annual Meeting and DPG Spring Meeting
Bonn, 15th - 19th of March 2010

Outline

- The Spin Structure of the Nucleon
- Generalized Parton Distributions (GPDs)
- Hard meson electroproduction
- Exclusive ρ^0 production at Hermes with the Recoil Detector at Hermes
 - b Slop with & without Recoil Detector
- Outlook

The Spin Structure of the Nucleon

$$S_z = \frac{1}{2} = J_q + J_g = \frac{1}{2} \Delta\Sigma + L_q + J_g$$

■ $\Delta\Sigma$ Spin of quarks

■ $\Delta\Sigma = 0.330 \pm 0.011(\text{theo.}) \pm 0.025(\text{exp.}) \pm 0.028(\text{evol.})$

Airapetian et al. [HERMES Collaboration]

Phys. Rev. D 75, 012007 (2007)

■ L_q Orbital angular momentum

■ $J_{q,g}$ Total orbital angular momentum

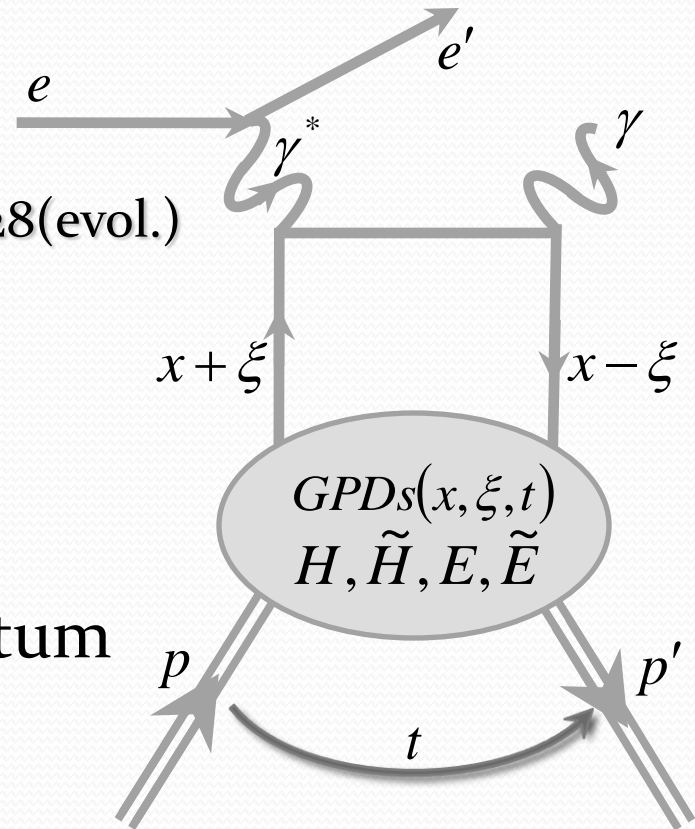

Generalized Parton Distributions

Ji Relation *Ji, Phys. Rev. Lett. 78, 610 - 613 (1997)*

$$J_q = \lim_{t \rightarrow 0} \int_{-1}^1 x dx \{H_q(x, \xi, t) + E_q(x, \xi, t)\}$$

$$J_g = \lim_{t \rightarrow 0} \int_0^1 dx \{H_g(x, \xi, t) + E_g(x, \xi, t)\}$$

$x \pm \xi$ parton longitudinal momentum fractions

ξ fraction of the momentum transfer

t invariant momentum transfer to the nucleon

H_q, \tilde{H}_q conserve nucleon helicity

E_q, \tilde{E}_q flip nucleon helicity

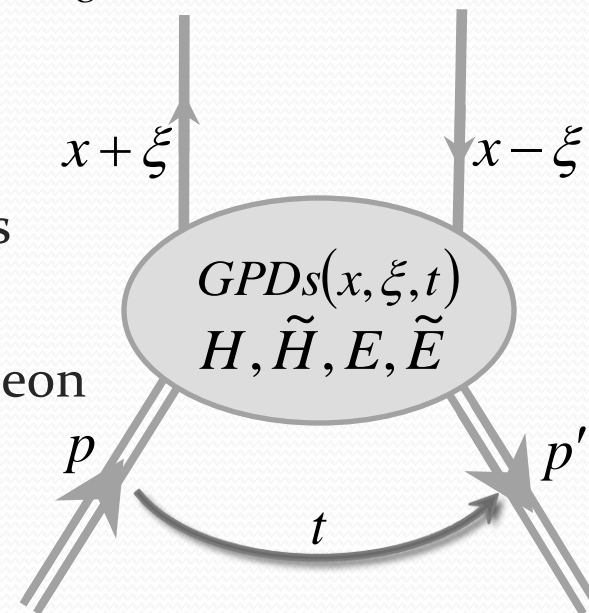

Hard meson electroproduction

- The quark helicity is conserved in hard scattering process
- The meson acts as a helicity selector:
 - The longitudinally polarized vector meson channels ($\rho_L^{0,\pm}$, ω_L , ϕ_L) are sensitive only to the unpolarized GPDs (H and E)
 - The pseudo-scalar channels ($\pi^{0,\pm}$, η , ...) are sensitive only to the polarized GPDs (\tilde{H} and \tilde{E})
- DVCS depends on both, the unpolarized (H and E) and polarized (\tilde{H} and \tilde{E}) GPDs.
- Hard meson electroproduction reactions are complementary to the DVCS process, as they provide an additional tool to disentangle the different GPDs.

K. Goeke, M V. Polyakov, M. Vanderhaeghen, Prog.Part.Nucl.Phys.47,401-515(2001)

Advantage of exclusive ρ^0 production

- the only process where the gluon contribution enters in LO
- exclusive ρ^0 sensitive to $H_{q,g}$ and $E_{q,g}$ at the same order in α_s

M. Diehl, A. V. Vinnikov, Phys.Lett.B609,286-290,(2005)

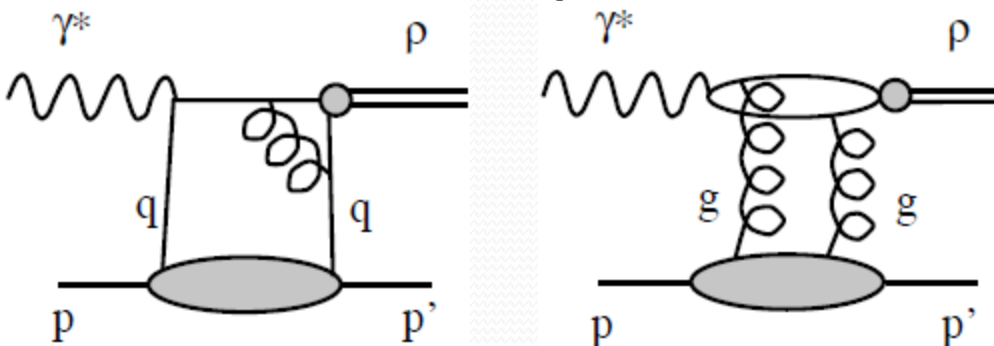

quark exchange
two-gluon exchange
models inspired by perturbative QCD

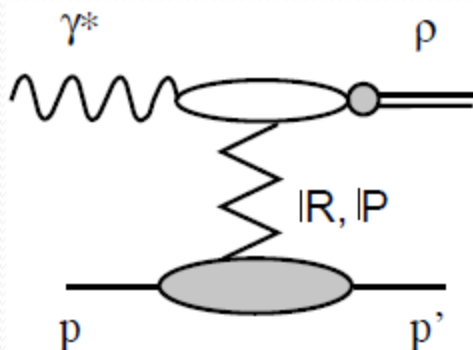

Reggeon or Pomeron exchange in
models based on Regge theory

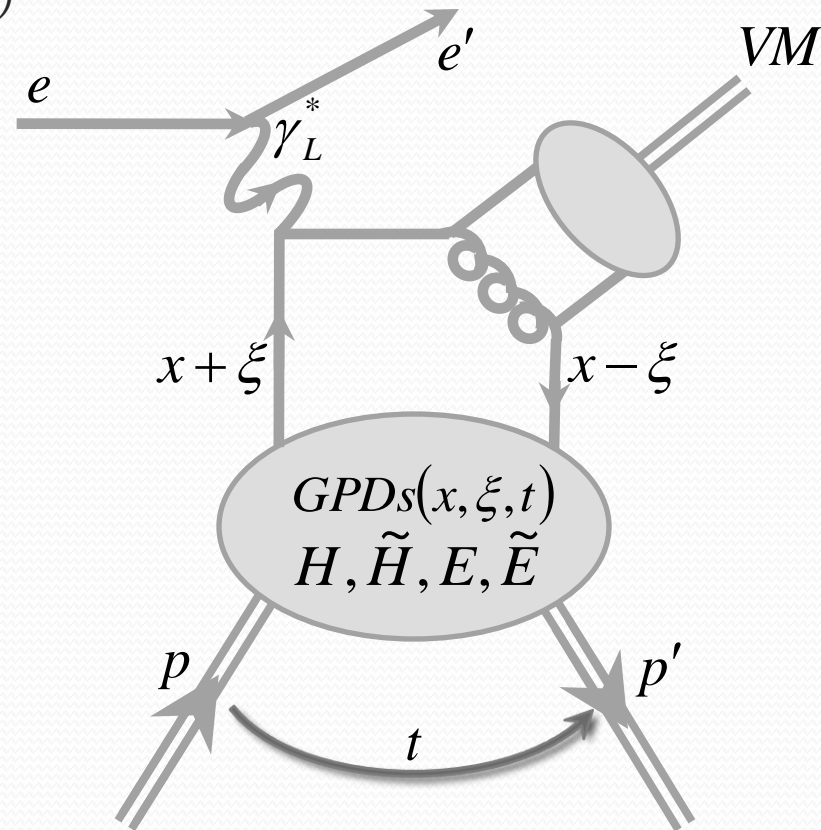

Exclusive ρ^0 production at Hermes

$$ep \rightarrow e'p\rho^0, \rho^0 \rightarrow \pi^+\pi^-$$

- exclusive events: main contribution at small values of $\Delta E = E_e + E_p - E_{e'} - E_\rho - E_{p'}$ and $t' = t - t_0$
- non-exclusive events ($\Delta E > 0$) contribute due to the experimental resolution and restricted acceptance
- Event produced in non-exclusive processes as an estimate of background size: **11%**

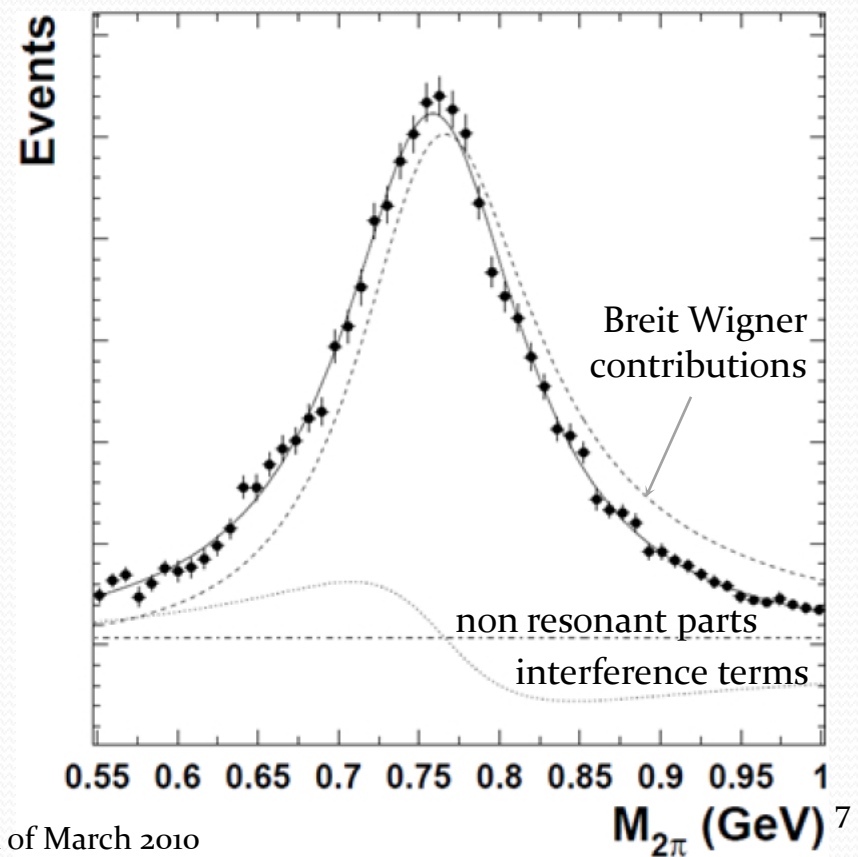
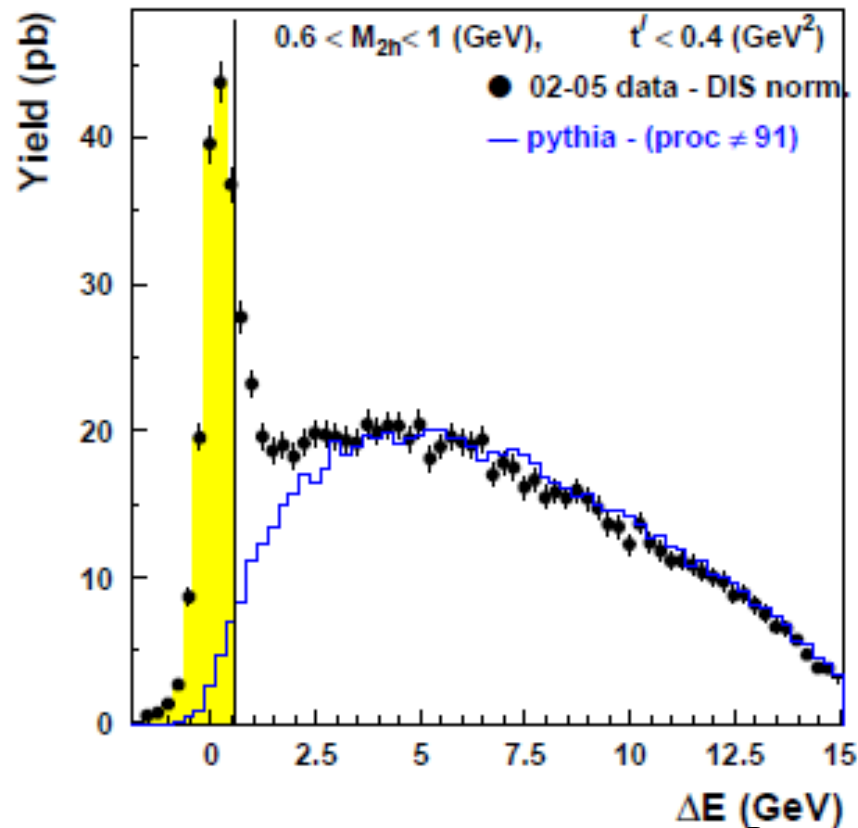

Hermes with Recoil Detector

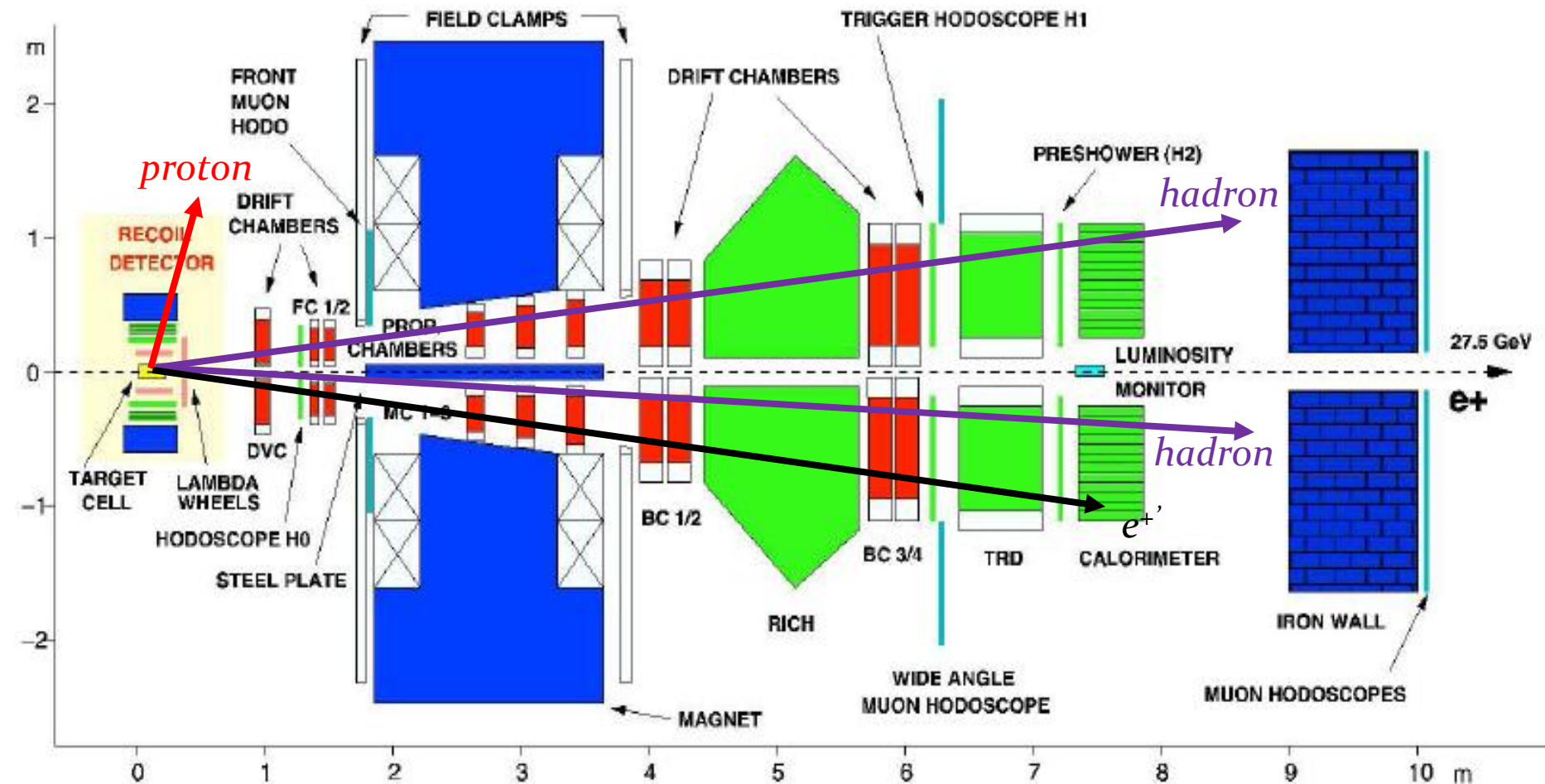

- Unpolarized hydrogen target: 38Mio DIS
- Unpolarized deuterium target: 10Mio DIS
- Two beam helicities, electron and positron beam

Recoil Detector at Hermes

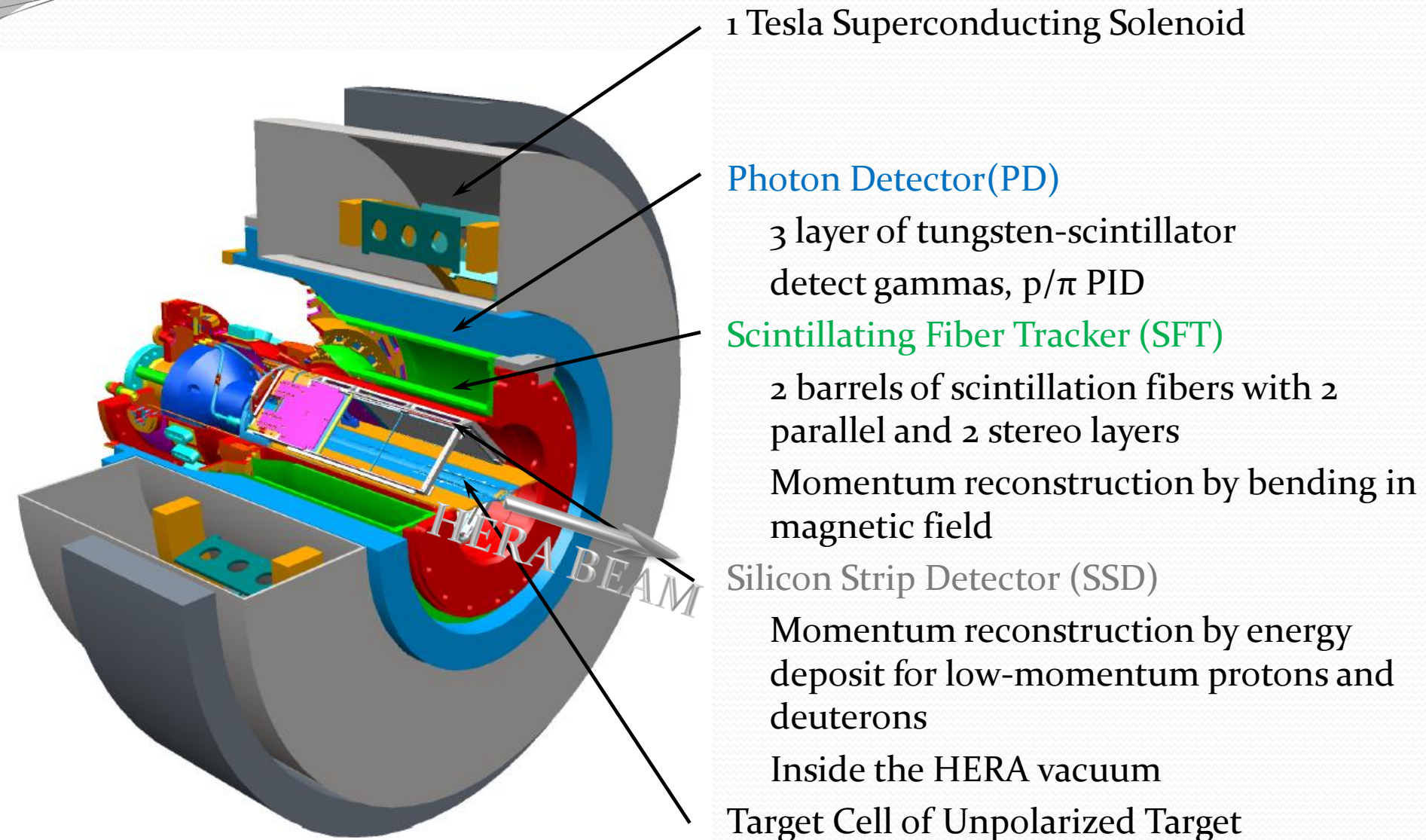

ΔE distributions with only Forward Spectrometer

$$0.6 < M(\pi^+ \pi^-) < 1.0$$

$$1.04 < M(KK)$$

$$7.0 < \text{Energy of vector meson}$$

$$3.5 < \text{momentum of lepton}$$

$$-t' < 0.4$$

$$7.0 > q^2 > 0.5$$

$$w^2 > 7$$

$$Y_{\text{bjorn}} > 0.85$$

$$5\text{cm} < Z \text{ Vertex} < 20 \text{ cm}$$

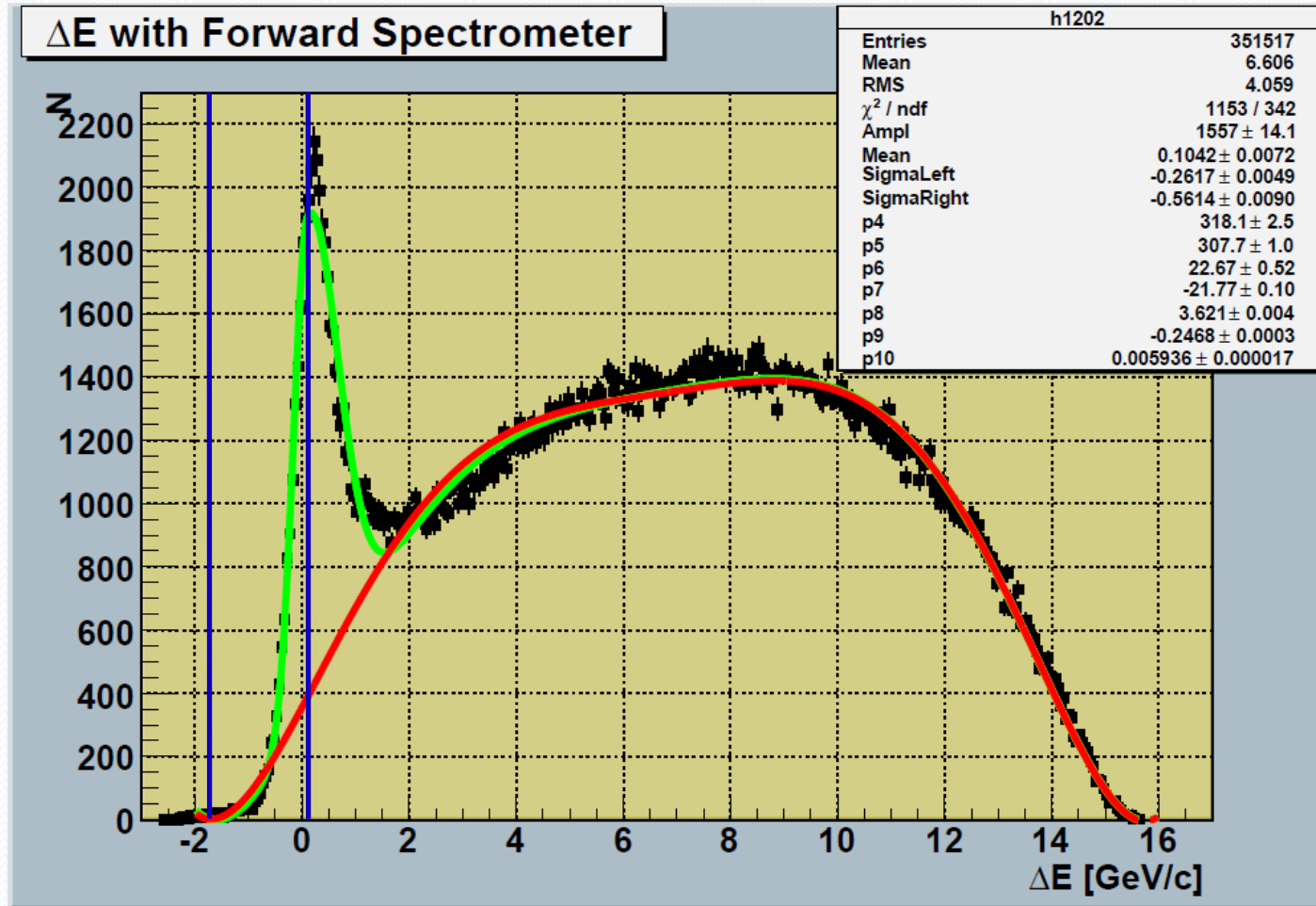

$$-1 < \Delta E < 0.6$$

ΔE distributions with cuts on Recoil Protons

$$0.6 < M(\pi^+ \pi^-) < 1.0$$

$$1.04 < M(KK)$$

$$7.0 < \text{Energy of vector meson}$$

$$3.5 < \text{momentum of lepton}$$

$$-t' < 0.4$$

$$7.0 > q^2 > 0.5$$

$$w^2 > 7$$

$$y_{\text{bjorn}} > 0.85$$

$$5\text{cm} < Z \text{ Vertex} < 20 \text{ cm}$$

$$5\text{cm} < Z \text{ Vertex Recoil} < 20 \text{ cm}$$

ΔE with Proton on Recoil Detector

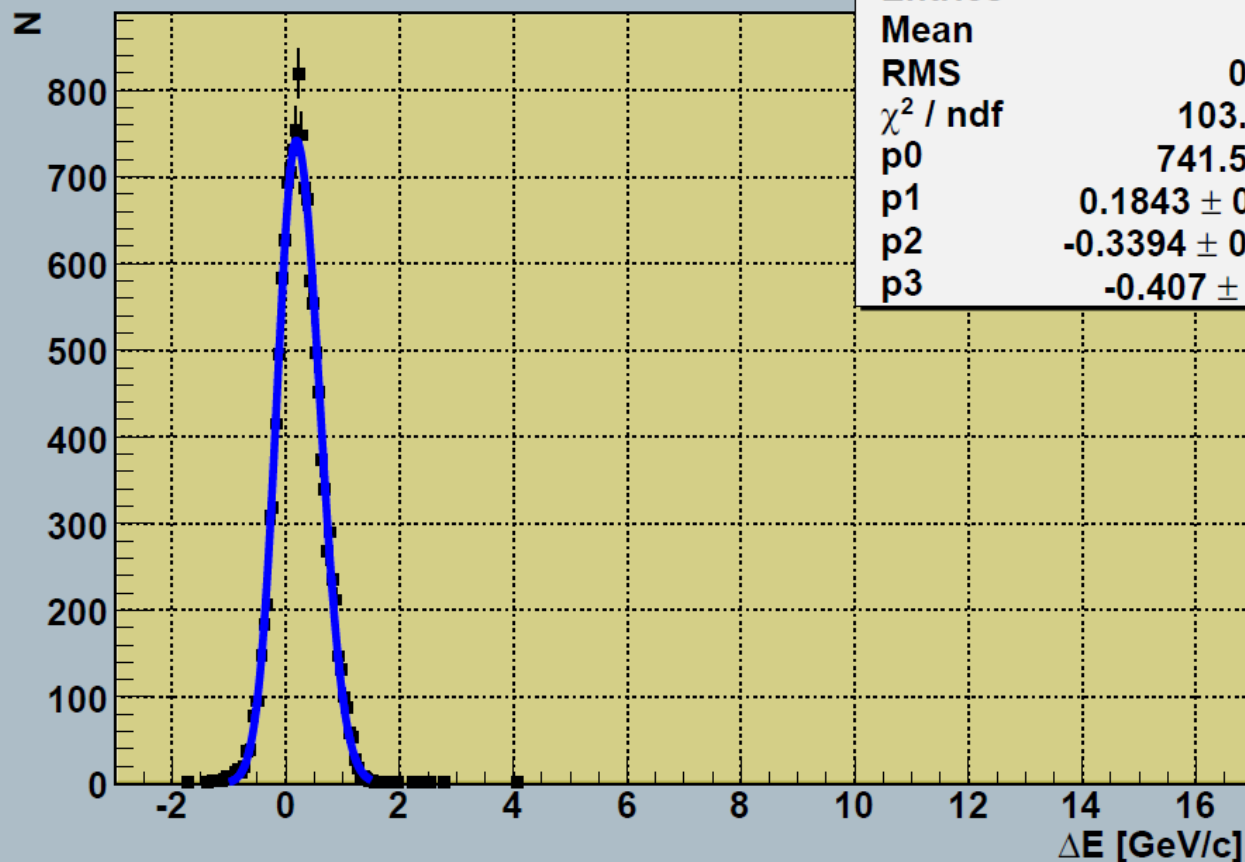

h1201

Entries	14005
Mean	0.238
RMS	0.3865
χ^2 / ndf	103.2 / 46
p0	741.5 ± 7.8
p1	0.1843 ± 0.0081
p2	-0.3394 ± 0.0055
p3	-0.407 ± 0.005

Cuts on the recoil proton

$$-1\text{GeV} < \Delta P < 1\text{GeV}$$

$$-0.1 \text{ rad} < \Delta\phi < 0.1 \text{ rad}$$

ρ^0 mass distributions with cut on Recoil Protons

$$0.3 < M(\pi^+ \pi^-) < 1.2$$

$$1.04 < M(KK)$$

$$7.0 < \text{Energy of vector meson}$$

$$3.5 < \text{momentum of lepton}$$

$$-t' < 0.4$$

$$7.0 > q^2 > 0.5$$

$$w^2 > 7$$

$$Y_{\text{bjorn}} > 0.85$$

$$5\text{cm} < Z \text{ Vertex} < 20 \text{ cm}$$

$$5\text{cm} < Z \text{ Vertex Recoil} < 20 \text{ cm}$$

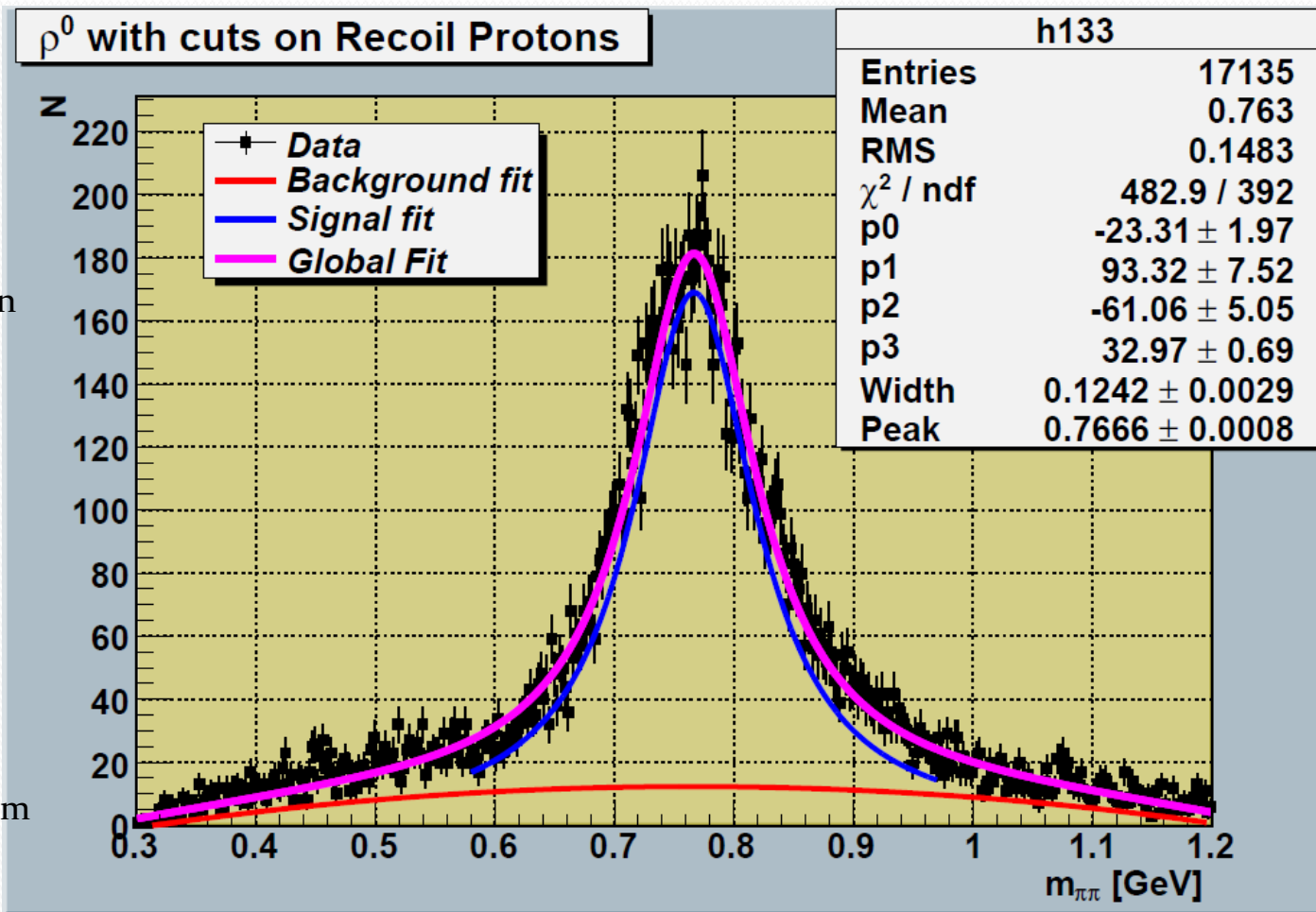

Cuts on the recoil proton

$$-1\text{GeV} < \Delta P < 1\text{GeV}$$

$$-0.1 \text{ rad} < \Delta < 0.1 \text{ rad}$$

$$\text{mass } \rho(770) = 775.49 \pm 0.34 \text{ MeV}$$

C. Amsler *et al.* (Particle Data Group), PL B667, 1 (2008)

The slope parameter b is a measure of the transverse size of the ρ^0 vector meson ($b = 1/3 (\langle r_{\rho^0}^2 \rangle + \langle r_p^2 \rangle)$), where $\langle r_p^2 \rangle$ is a measure of the transverse size of the proton.

In certain theoretical models, $b(Q^2)$ is needed to check the $-t'$ dependence of GPDs Slope

*Extraction and Separation of Exclusive ρ_L^0 and ρ_T^0
B.Ball, A. Airapetian, W. Lorenzon, December 13, 2007*

b Slop with only Forward Spectrometer

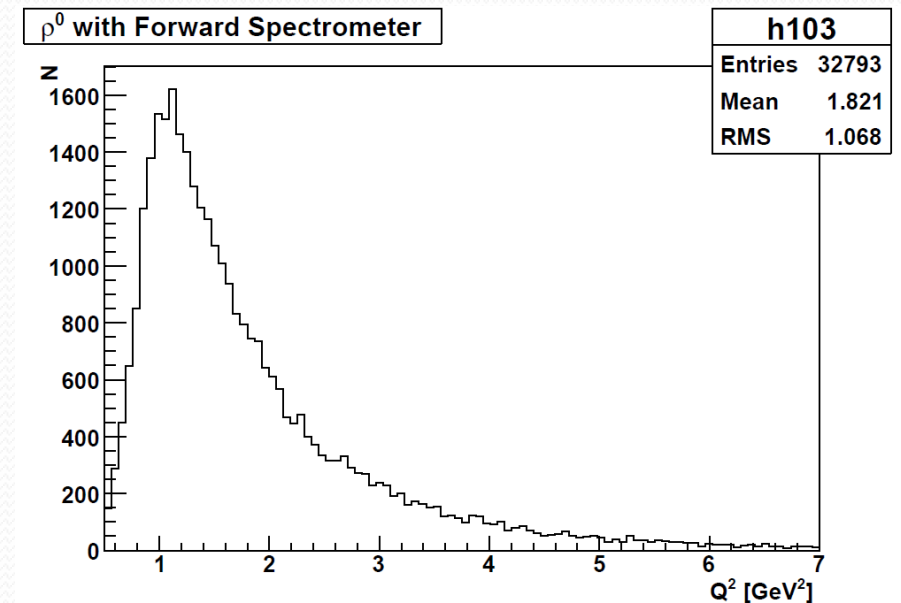
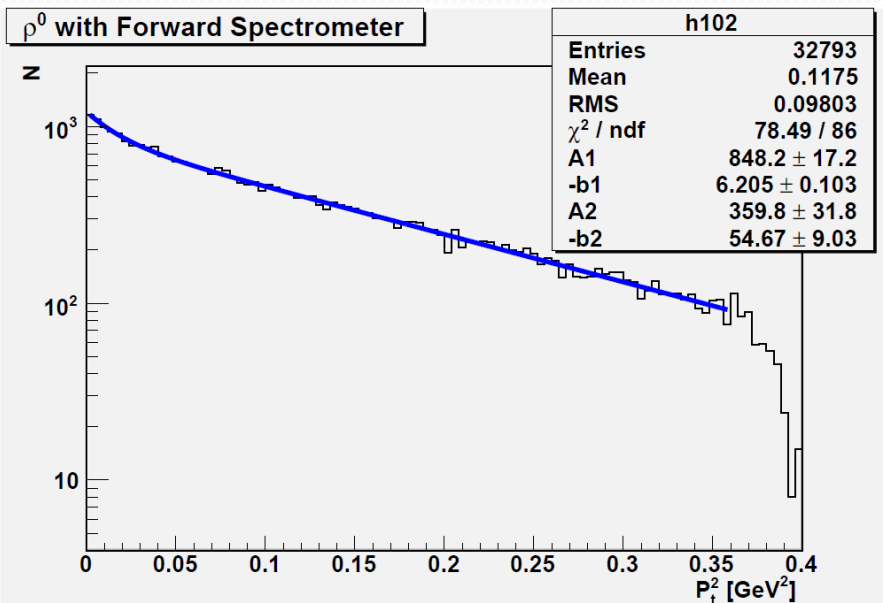
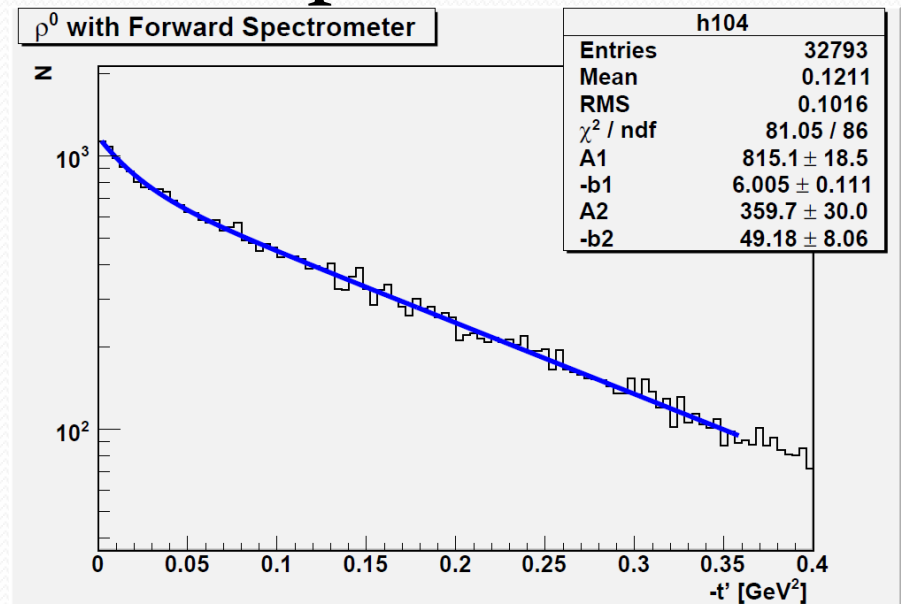
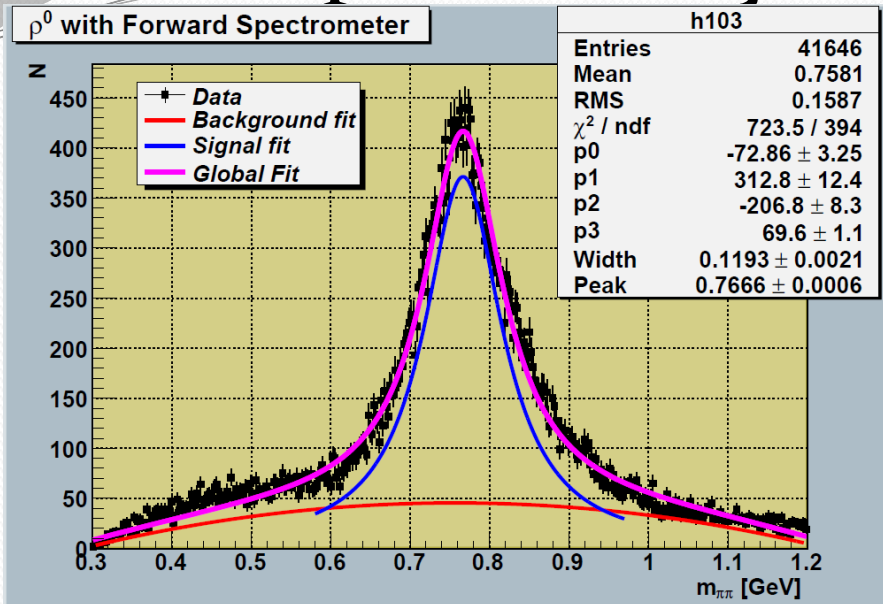

b Slop with cut on Recoil Protons

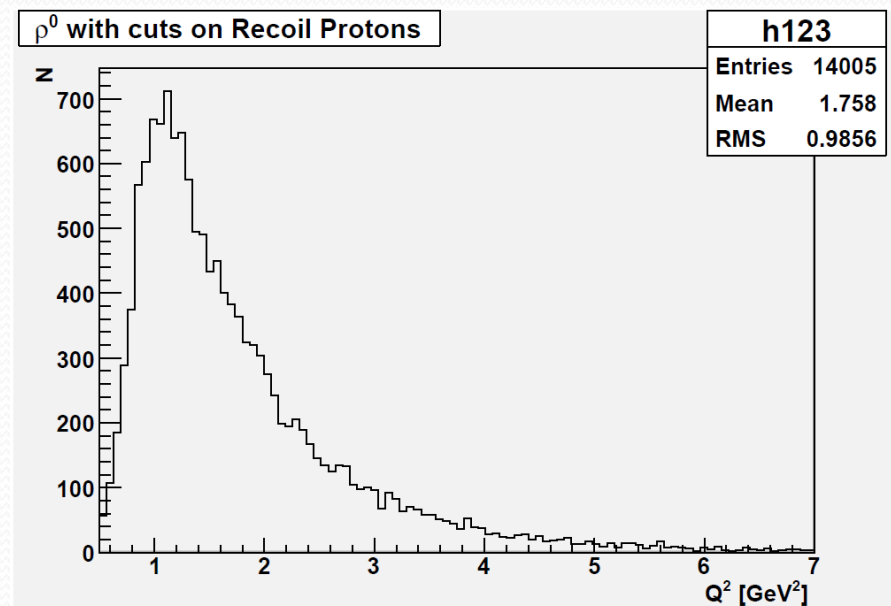
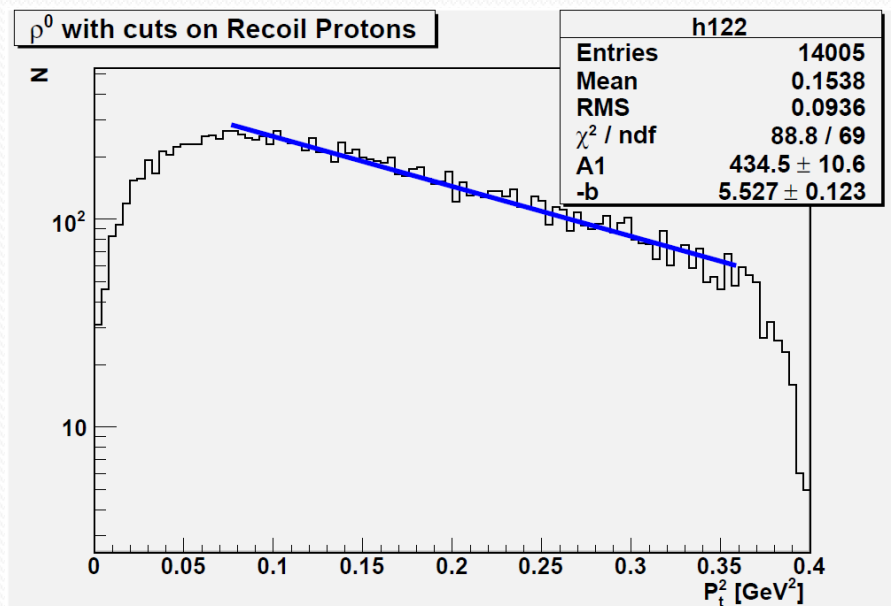
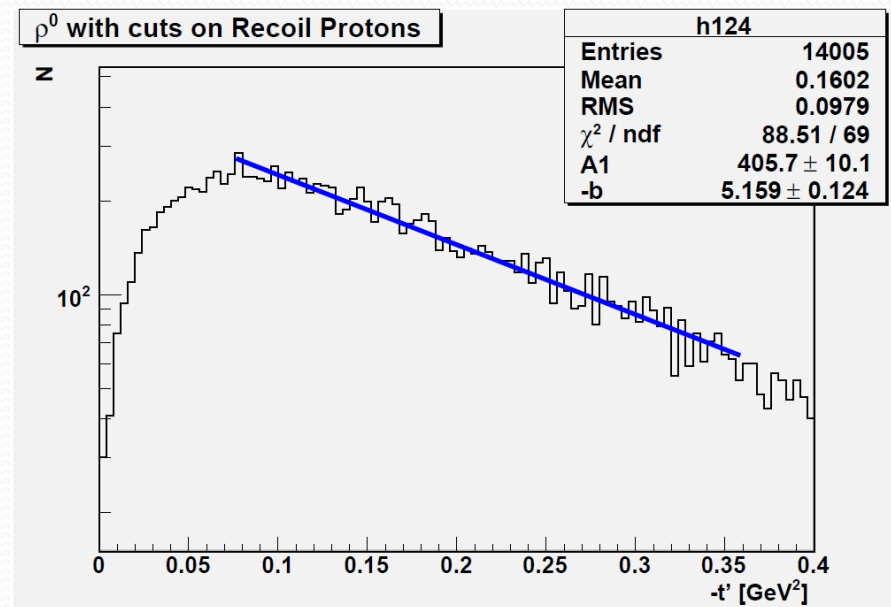
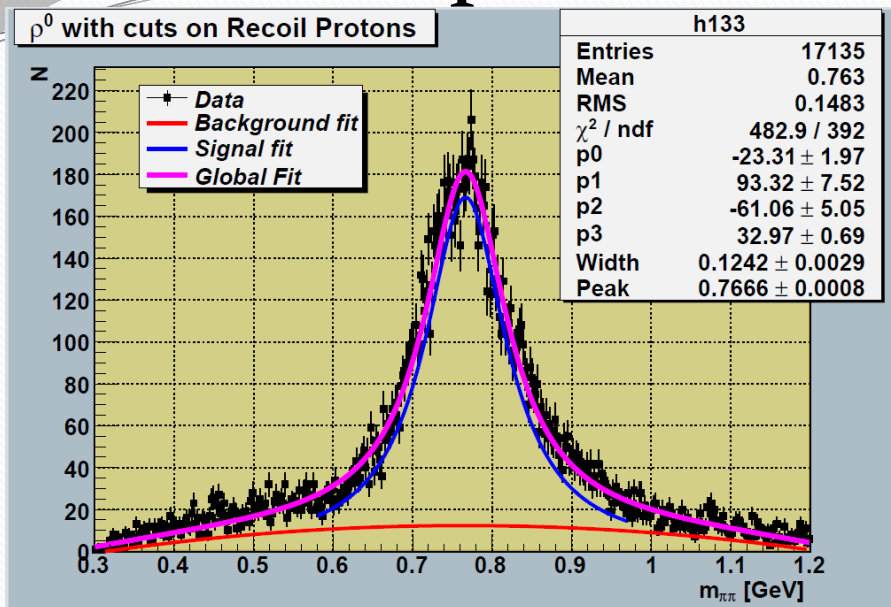

Summary and Outlook

- New data from Hermes using the Recoil Detector are ready for physics analysis
- Exclusive ρ^0 production with the Recoil Detector
- b slope analysis of exclusive ρ^0 production